

Instruction Manual



INSTALLATION INSTRUCTIONS FOR EMS P/N 30-6101 1993-1998 Toyota Supra non-turbo 1993-1997 Lexus SC300/GS300



STOP!

THIS PRODUCT HAS LEGAL RESTRICTIONS.
READ THIS BEFORE INSTALLING/USING!

WARNING! THIS IS A RACE ONLY PRODUCT MANUFACTURED AND SOLD FOR INSTALLATION ON VEHICLES DESIGNED TO BE USED SOLELY FOR COMPETITION PURPOSES. ONCE THIS PART IS INSTALLED, THE VEHICLE MAY NEVER BE USED, OR REGISTERED OR LICENSED FOR USE, ON A PUBLIC ROAD OR HIGHWAY. IF YOU INSTALL THIS PART ON YOUR VEHICLE AND USE THE VEHICLE ON A PUBLIC ROAD OR HIGHWAY, YOU WILL VIOLATE THE CLEAN AIR ACT AND MAY BE SUBJECT TO PERSONAL CIVIL OR CRIMINAL LIABILITY, INCLUDING FINES OF UP TO \$4,819 PER DAY.

IT IS THE RESPONSIBILITY OF THE INSTALLER AND/OR USER OF THIS PRODUCT TO ENSURE THAT IT IS USED IN COMPLIANCE WITH ALL APPLICABLE LAWS AND REGULATIONS. IF THIS PRODUCT WAS PURCHASED IN ERROR, DO NOT INSTALL AND/OR USE IT. THE PURCHASER MUST ARRANGE TO RETURN THE PRODUCT FOR A FULL REFUND.

THIS POLICY ONLY APPLIES TO INSTALLERS AND/OR USERS WHO ARE LOCATED IN THE UNITED STATES; HOWEVER CUSTOMERS WHO RESIDE IN OTHER COUNTRIES SHOULD ACT IN ACCORDANCE WITH THEIR LOCAL LAWS AND REGULATIONS.

WARNING!

Improper installation and/or adjustment of this product can result in major engine/vehicle damage. For technical assistance visit our dealer locator to find a professional installer/tuner near you.

Note: AEM holds no responsibility for any engine damage or personal injury that results from the misuse of this product, including but not limited to injury or death.

Thank you for purchasing an AEM Engine Management System.

The AEM Engine Management System (EMS) is the result of extensive development on a wide variety of cars. Each system is engineered for the particular application. The AEM EMS differs from all others in several ways. The EMS is a standalone system that completely replaces the factory ECU and features unique Plug and Play Technology, which means that each system is configured especially for your make and model of car without any jumper harnesses. There is no need to modify your factory wiring harness and in most cases your car may be returned to stock in a matter of minutes.

For stock and slightly modified vehicles, the supplied startup calibrations are configured to work with OEM sensors, providing a solid starting point for beginner tuning. For more heavily modified cars, the EMS can be reconfigured to utilize aftermarket sensors and has many spare inputs and outputs allowing the elimination of add-on rev-limiters, boost controllers, nitrous controllers, fuel computers, etc. It also includes a configurable onboard 1MB data logger that can record any 16 EMS parameters at up to 250 samples per second. Every EMS comes with all functions installed and activated; there is no need to purchase options or upgrades to unlock the full potential of your unit.

The installation of the AEM EMS on the supported vehicles uses the stock sensors and actuators. After installing the AEMTuner software, the startup calibration will be saved to the following folder on your PC:

C:\Program Files\AEM\AEMTuner\Calibrations\Toyota” in the AEMTuner

Multiple calibrations may be supplied for each EMS; additional details of the test vehicle used to generate each calibration can be found in the Calibration Notes section for that file.

Please visit the AEM Performance Electronics Forum at <http://www.aempower.com> and register. We always post the most current strategy release, PC Software and startup calibrations online. On the forum, you can find and share many helpful hints/tips to make your EMS perform its best.

TUNING NOTES AND WARNING:

While the supplied startup calibration may be a good starting point and can save considerable time and money, it will not replace the need to tune the EMS for your specific application. AEM startup calibrations are not intended to be driven aggressively before tuning. We strongly recommend that every EMS be tuned by someone who is already familiar with the AEM software and has successfully tuned vehicles using an AEM EMS. Most people make mistakes as part of the learning process; be warned that using your vehicle as a learning platform can damage your engine, your vehicle, and your EMS.

Read and understand these instructions **BEFORE** attempting to install this product.

1) Install AEMTuner software onto your PC

The latest version of the AEMTuner software can be downloaded from the 'Current AEMTuner Software & Discussion' section of the AEM Performance Electronics forums. Series 2 units are not supported by the older AEMPro tuning software.

2) Remove the Stock Engine Control Unit

- a) Access the stock Engine Control Unit (ECU). The location of the ECU on the Supra is behind the passenger side kick panel.
- b) Carefully disconnect the wiring harness from the ECU. Avoid excessive stress or pulling on the wires, as this may damage the wiring harness. Some factory ECUs use a bolt to retain the factory connectors, and it must be removed before the harness can be disconnected. There may be more than one connector, and they must all be removed without damage to work properly with the AEM ECU. Do not cut any of the wires in the factory wiring harness to remove them.
- c) Remove the fasteners securing the ECU to the car body, and set them aside. Do not destroy or discard the factory ECU, as it can be reinstalled easily for street use and troubleshooting.

3) Install the AEM Engine Management System

- a) Plug the factory wiring harness into the AEM EMS and position it so the wires are not pulled tight or stressed in any manner. Secure the EMS with the provided Velcro fasteners.
- b) Plug the communications cable into the EMS and into your PC.
- c) Turn the ignition on but do not attempt to start the engine.
- d) At the time these instructions were written, new EMS units do not require USB drivers to be installed to the PC.
- e) With the AEMTuner software open, select **ECU>>Upload Calibration** to upload the startup calibration file (.cal) that most closely matches the vehicle's configuration to be tuned. Check the Notes section of the calibration for more info about the vehicle it was configured for. These files can be found in the following folder:
C:\Program Files\AEM\AEMTuner\Calibrations\Toyota
- f) Set the throttle range: Select Wizards>>Set Throttle Range and follow the on-screen instructions. When finished, check that the 'Throttle' channel never indicates less than 0.2% or greater than 99.8%, this is considered a sensor error and may cause some functions including idle feedback and acceleration fuel to operate incorrectly.

4) Wiring Accessories to the EMS:

Please follow this suggested wiring diagram when adding accessories such as UEGO gauges, MAP sensors, IAT sensors, or switches for use with the EMS. Signals marked 'tapped' should be spliced onto the existing wire without disconnecting the original circuit. All other signals should intercept the wire, disconnecting the original circuit. Note that wire polarity is not important for the Air Temperature sensor.

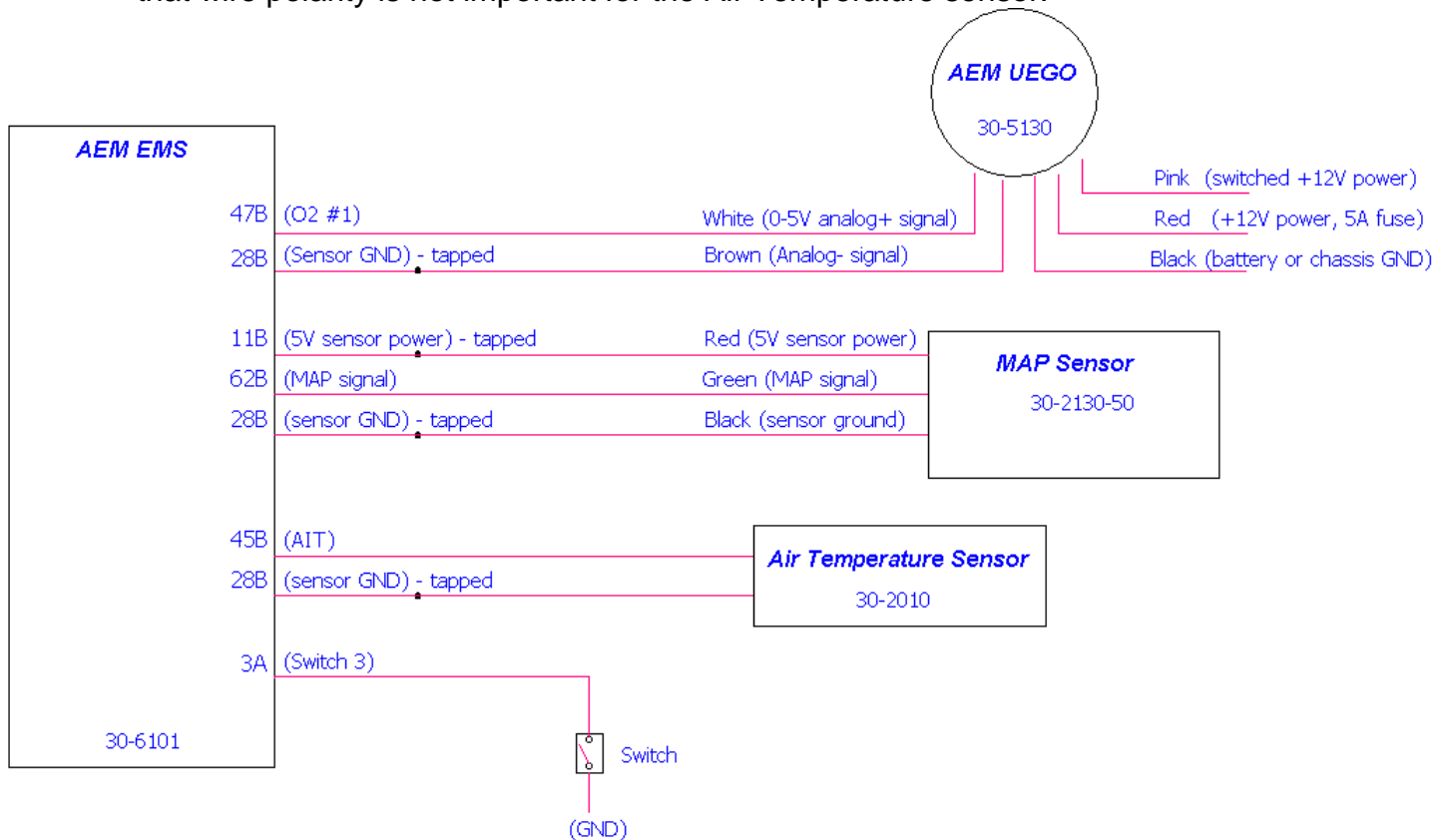

5) Ready to begin tuning the vehicle.

- Before starting the engine, verify that the fuel pump runs for at least 2 seconds when the key is turned on and there is sufficient pressure at the fuel rail.
If a MAP sensor is installed, check that the Engine Load indicates something near atmospheric pressure (approximately 101kPa or 0 PSI at sea level) with the key on and engine off. Press the throttle and verify that the 'Throttle' channel responds but the Engine Load channel continues to measure atmospheric pressure correctly.
- Start the engine and make whatever adjustments may be needed to sustain a safe and reasonably smooth idle.
Verify the ignition timing: Select **Wizards>>Ignition Timing Sync Wizard** from the pull-down menu. Click the '*Lock Ignition Timing*' checkbox and set the timing to a safe and convenient value (for instance, 10 degrees BTDC). Use a timing light and compare the physical timing (measured at the crankshaft pulley) vs the Ign Timing value indicated by the EMS. Use the *Sync Adjustment Increase/Decrease* buttons to ensure the actual timing on the crankshaft pulley matches the 'Ign Timing' channel indicated by the EMS.
- Note: This calibration needs to be properly tuned before driving the vehicle. It is intended for racing vehicles and may not operate smoothly at idle or part-throttle.
NEVER TUNE THE VEHICLE WHILE DRIVING

6) Troubleshooting an engine that will not start

- a) Double-check all the basics first... engines need air, fuel, compression, and a correctly-timed spark event. If any of these are lacking, we suggest checking simple things first. Depending on the symptoms, it may be best to inspect fuses, sufficient battery voltage, properly mated wiring connectors, spark using a timing light or by removing the spark plug, wiring continuity tests, measure ECU pinout voltages, replace recently-added or untested components with known-good spares. Check that all EMS sensor inputs measure realistic temperature and/or pressure values.
- b) If the EMS is not firing the coils or injectors at all, open the Start tab and look for the 'Stat Sync'd' channel to turn ON when cranking. This indicates that the EMS has detected the expected cam and crank signals; if Stat Sync'd does not turn on, monitor the Crank Tooth Period and T2PER channels which indicate the time between pulses on the Crank and T2 (Cam) signals. Both of these channels should respond when the engine is cranking, if either signal is not being detected or measuring an incorrect number of pulses per engine cycle the EMS will not fire the coils or injectors.
- c) If the Engine Load changes when the throttle is pressed this usually indicates that there is a problem with the MAP sensor wiring or software calibration (when the EMS detects that the MAP Volts are above or below the min/max limits it will run in a failsafe mode using the TPS-to-Load table to generate an artificial Engine Load signal using the Throttle input). This may allow the engine to sputter or start but not continue running properly.

**Application Notes for EMS P/N 30-6101
1993-1997 Supra, Lexus GS300, Lexus SC300**

Make:	Toyota
Model:	Supra/SC300/GS300
Years Covered:	1993-1997
Engine Displacement:	3.0L
Engine Configuration:	Inline 6
Firing Order:	1-5-3-6-2-4
N/A, S/C or T/C:	Naturally Aspirated
Load Sensor Type:	MAF
Number of Coils:	1 (Distributed spark)
Ignition driver type:	0-5V Falling Edge trigger
Number of Injectors:	6 (Inj 1-6)
Injector Flow Rate:	320 cc/min
Injector Resistance:	13-15 Ω
Injection Mode:	Sequential
Knock Sensors used:	1 & 2
Lambda Sensors used:	1 & 2
Idle Motor Type:	Stepper
Main Relay Control:	Yes (HS2 output)
Crank Pickup Type:	Magnetic (2-wire)
Crank Teeth per Cycle:	24
Cam Pickup Type:	Magnetic (2-wire)
Cam Teeth per Cycle:	1
Transmissions Offered:	M/T, A/T
Trans Supported:	M/T only
Drive Options:	RWD
Spare pins:	AEM PN 3-1275-S
ECU extension harness	AEM PN 30-2994

Spare Injector Drivers:	Inj 7, Pin 70B
Spare Injector Drivers:	Inj 8, Pin A36
Spare Injector Drivers:	Inj 9, Pin 74B (EVAP wire)
Spare Injector Drivers:	Inj 10, Pin 75B(EGR wire)
Spare Injector Drivers:	Inj 11, Pin A19
Spare Injector Drivers:	Inj 12, Pin A17
Spare Coil Drivers:	Coil2, pin 56B
Spare Coil Drivers:	Coil3, pin 55B
Spare Coil Drivers:	Coil4, pin 54B
Spare Coil Drivers:	Coil5, pin 53B
Spare Coil Drivers:	Coil6, pin 52B
Boost Solenoid:	PW2, Pin 60B
EGT #1 Location:	Pin 2B
EGT #2 Location:	Pin 4B
EGT #3 Location:	Pin 8B
EGT #4 Location:	Pin 67B
Spare 0-5V Channels:	MAP, Pin 62B
Spare 0-5V Channels:	ADCR12, Pin 29A
Spare 0-5V Channels:	ADCR14, Pin 24B (2.2kΩ P/U)
Spare Low Side Driver:	Low Side 4, Pin 38B
Spare Low Side Driver:	Low Side 3, Pin 40B
Spare Low Side Driver:	Low Side 7, Pin 38A
Spare Low Side Driver:	Low Side 9, Pin 68B
Spare Low Side Driver:	Low Side 11, Pin 59B
Check Engine Light:	Low Side 10, Pin 6A
Spare Switch Input:	Switch 3, Pin 3A
Spare Switch Input:	Switch 6, Pin 4A
A/C Switch Input:	Switch 7 (ADCR11) Pin 34A

Primary Load Sensor

AEM recommends installing an aftermarket MAP sensor for vehicles that will be turbocharged, please see the wiring diagram on page 3 and use the startup calibration that includes 'AEM 3.5Bar MAP' in the filename.

The frequency-type Volume Airflow Meter found on 1993-1995 vehicles is not supported. If the vehicle will remain naturally aspirated, please use the startup calibration that includes 'Alpha-N' in the filename. The Alpha-N calibration uses the throttle position sensor for the main load input on the fuel map. Using the throttle sensor for load is not ideal for idle quality or drivability, but it tends to work well for naturally aspirated racecars that utilize aggressive cams.

For 1996-1997 vehicles, the Toyota hot-wire Mass Air Flow (MAF) sensor is used as the load input in the startup calibration that includes 'MAF' in the filename. The channel 'MAF as Load' must be used to view engine load and the 'Fuel MAF' table must be used to adjust fueling.

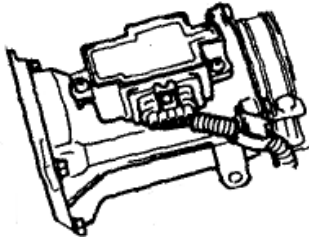

Frequency-type Airflow Meter (1993-1995)

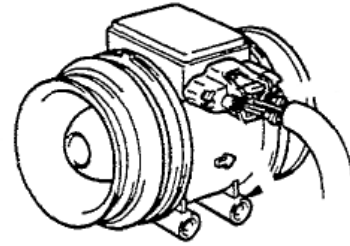

Hot-wire MAF (1996-1997)

EMS Fuel Map, Boost Fuel Trim Table

The 30-6101 MAP calibration provided utilizes the "Boost Fuel Trim Table" to provide a 1:1 fuel compensation above and below atmospheric pressure. In the startup calibration, the "Boost Fuel Trim Table" is configured to provide twice as much fuel when the manifold pressure is twice as high; this should help simplify the tuning process for different boost levels. Notice the values in the main "Fuel Map" do not change significantly above 100 kPa (0 psi boost), the fuel correction is being made by the "Boost Fuel Trim Table." Note: the "Boost Fuel Trim Table" must be adjusted if a different map sensor is installed or if the Load breakpoints are adjusted. The Boost Fuel Correct value should be set to -75 at 25kPa, 0 at 100 kPa, +100 at 200 kPa, +200 at 300 kPa, etc...

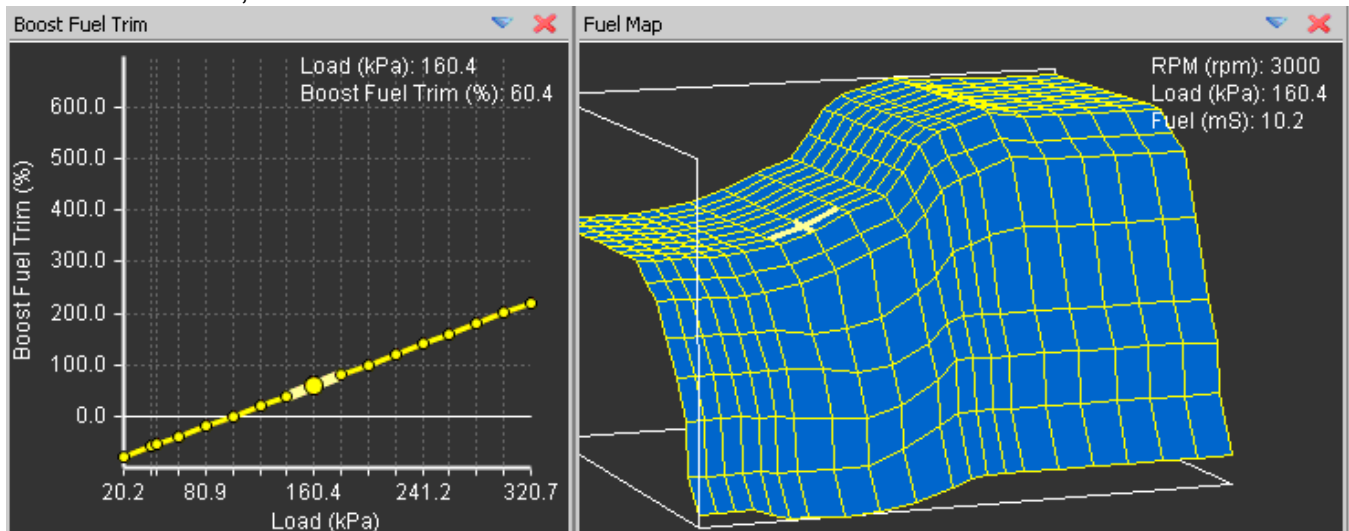

Fuel Pump Control

As supplied from Toyota, the OEM ECU interfaces with a fuel pump ECU to control the speed, high or low, of the fuel pump based on load. The AEM EMS has the ability to replicate this functionality; however it is configured in the Startup Calibration to run the fuel pump at high speed at all times.

The EMS Output COIL8 (Pin 22A) is used to send a 5V signal instructing the OEM fuel pump ECU to energize the fuel pump. Configuring *User PW Out* to use LS8 and, for example, *User PW Analog In* to MAP Volts will allow the voltage sent to the fuel pump ECU to be varied in relation to MAP Volts/pressure. Increasing the duty cycle of the LS8 output will decrease the speed of the fuel pump.

WARNING: Reducing the voltage sent to the fuel pump can affect fuel pump output (volume and/or pressure). If you wish to decrease pump speed, monitor fuel pressure and air-fuel ratio very carefully to avoid engine damage!

WARNING: Do not use pin 22A to control a fuel pump relay directly, it must be connected to the OEM fuel pump ECU only. If an aftermarket fuel pump relay will be installed, wire it to be controlled using a spare low side output (for instance, LS9 is available on pin 68B). Be sure to configure the output to use the Fuel Pump function using Tools>>Configure Outputs.

Peak and Hold Injector Drivers

Injectors 1-12 include Peak (4 amps) and Hold (1 amp) injector drivers. These drivers may be used with peak and hold or saturated type injectors. The factory Toyota wiring harness for some vehicles may contain a resistor pack to prevent excessive current when using low-impedance injectors with the stock ECU. With the 30-6101 installed, users can elect to remove and bypass the OEM resistor pack for more precise control of low-impedance injectors.

Please note that the injector response time will be different with and without the factory injector resistor pack. If the OEM resistor pack has been removed and bypassed, please choose the correct battery offset for your injectors using the Setup Wizard. Most battery offset wizard configurations will specify <P&H DRIVER> if they are intended for use without a resistor pack.

Connection Diagram for EMS P/N 30-6101

Pin#	93-97 Supra/Lexus 2JZ-GE	AEM P/N 30-6101	I/O	Availability & Notes
1A	Ignition Switch (+12V when key on)	Main Relay circuit	Input	Dedicated, activates Switch 1 input
2A	Vehicle Speed Signal – from Odo/Trip meter	T3 (Vehicle Speed)	Input	PnP for Vehicle Speed signal
3A	Kickdown switch	Switch 3	Input	Available, switch must connect to GND
4A	Brake switch input (12V)	Switch 6	Input	Available, switch must connect to GND
5A	---	---	---	Not Used
6A	W- Malfunction Indicator Lamp	LS10	Output	Available, switched GND output (1.5A max)
7A	---	ATPR (GEAR)	Input	Reserved for future use
8A	SDL to datalink connector (96-97 only)	---	---	Not Used
9A	2nd gear indicator input (A/T only)	ATP2 (GEAR)	Input	Reserved for future use
10A	1st gear indicator input (A/T only)	ATP1 (GEAR)	Input	Reserved for future use
11A	---	CAN1L	Output	Dedicated
12A	OD1 to cruise control ECU (AT only)	CAN1H	Output	Dedicated
13A	---	Reserved	---	Reserved for future use
14A	---	Reserved	---	Reserved for future use
15A	ELS for Idle up Diode	---	---	Not Used
16A	Tacho signal (from ignitor)	---	---	Not Used
17A	TT sig to DATALINK connector (A/T only)	Injector 12	Output	Available, P&H Injector driver 4A/1A
18A	A/T pattern select sw (A/T only)	Switch 5	Input	Available, switch must connect to GND
19A	TE2 sig to DATALINK connector	Injector 11	Output	Available, P&H Injector driver 4A/1A
20A	TE1 sig to DATALINK connector	---	---	Not Used
21A	DI from Fuel Pump ECU	---	---	Not Used
22A	Fuel pump control (FPC) signal	Coil 8 / LS8	Output	PnP 0- 5V FPC signal, not for use with relays
23A	ACMG to A/C Magnetic clutch	LS6	Output	PNP for A/C compressor relay
24A	Main Relay Control	Main Relay (HS2)	Output	Dedicated, activates Main Relay with 12V
25A	Manual indicator light (A/T only)	ATIND (Coil7)	Output	PNP manual mode indicator (auto only)
26A	---	EFI-TRC	Input	Dedicated
27A	---	EFI+TRC	Input	Dedicated
28A	Over Drive Switch input (A/T only)	Switch 4	Input	PNP for Overdrive input (auto only)
29A	---	Baro (ADCR12)	Input	Available, Spare 0-5V Sensor Input
30A	Sub O2 signal (CA only)	---	---	Not Used
31A	+12V Power from main relay	+12V Switched	Both	Dedicated
32A	+12V Power from main relay	---	---	Not Used
33A	+12V permanent battery backup power	Permanent +12V	Input	Dedicated, used to store internal datalog
34A	A/C signal from A/C amplifier	ADCR11 (Switch 7)	Input	PNP for Air Conditioning request switch
35A	---	HALLPWR	Output	+12V Output
36A	Sub O2 sensor heater control (CA only)	Injector 8	Output	Spare P&H Injector 4A/1A
37A	---	---	---	Not Used
38A	---	LS7	---	Available, switched GND output (1.5A max)
39A	---	---	---	Not Used
40A	---	---	---	Not Used

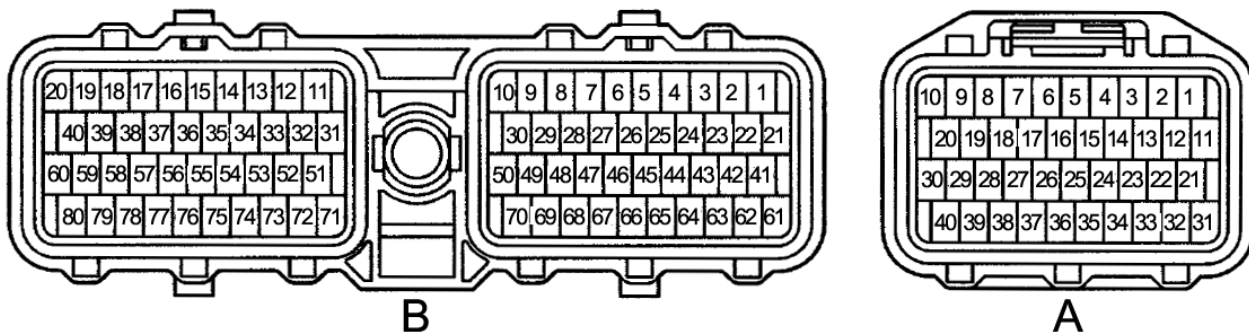

WARNING: pin labeling scheme follows Toyota service manual convention; diagram shows wire side of connector. Pin labels molded into plastic connector may not be accurate, check diagram carefully.

Connection Diagram for EMS P/N 30-6101

Pin#	93-97 Supra/Lexus 2JZ-GE	AEM P/N 30-6101	I/O	Availability & Notes
1B	---	Timing Ground	Output	Dedicated
2B	---	EGT 1	Input	Jumper set for 0-5V input (100kΩ pull-up)
3B	VSS Ground	Timing Ground	Output	Dedicated
4B	E11	EGT 2	Input	Jumper set for 0-5V input (100kΩ pull-up)
5B	Cam Sensor 2 (NE2) Ground	---	---	Not Used
6B	---	Timing Ground	Output	Dedicated
7B	Distributor Ground	Timing Ground	Output	Dedicated
8B	Auto Trans Sol No3 S3 (Auto Trans only)	EGT 3	Input	Jumper set for 0-5V input (100kΩ pull-up)
9B	Auto Trans Sol No2 S2 (Auto Trans only)	HS3	Output	Available, switched +12V output (1.5A max)
10B	Auto Trans Sol No1 S1 (Auto Trans only)	HS4	Output	Available, switched +12V output (1.5A max)
11B	---	+5V Sensor power	Output	Dedicated, sensor only
12B	---	Reserved	---	Reserved for future use
13B	---	Reserved	---	Reserved for future use
14B	---	Reserved	---	Reserved for future use
15B	Injector 6	Injector 6	Output	PnP Injector 6 (P&H 4A/1A driver)
16B	Injector 5	Injector 5	Output	PnP Injector 5 (P&H 4A/1A driver)
17B	Injector 4	Injector 4	Output	PnP Injector 4 (P&H 4A/1A driver)
18B	Injector 3	Injector 3	Output	PnP Injector 3 (P&H 4A/1A driver)
19B	Injector 2	Injector 2	Output	PnP Injector 2 (P&H 4A/1A driver)
20B	Injector 1	Injector 1	Output	PnP Injector 1 (P&H 4A/1A driver)
21B	---	Switch 2	Input	Available Switch input
22B	---	---	---	Not Used
23B	No.2 Speed sensor (Auto Trans only)	T4 (Spare Speed)	Input	Available magnetic speed sensor input
24B	Auto Trans Fluid Temp (Auto Trans only)	ADCR14	Input	Available 0-5V input, 2.2kΩ pull up to 5V
25B	Distributor Cam signal 2 (G2) input	---	---	Not Used
26B	Distributor Cam signal 1 (G1) input	Cam (T2) signal +	Input	Dedicated
27B	Distributor - Crank signal (NE) input	Crank signal +	Input	Dedicated
28B	VF2 sig – to Datalink connector 1 – pin14	Sensor Ground	Output	Dedicated, Sensors only
29B	VF1 sig – to DATALINK connector	IDLE7	Output	Available, switched Ground / +12V, 1.5A max
30B	---	IDLE8	Output	Available, switched +12V/Ground, 1.5A max
31B	---	+12V Switched	Output	Dedicated
32B	ISC4 (pin 3 on ISC harness)	IDLE4	Output	PNP Idle control motor,
33B	ISC3 (pin 6 on ISC harness)	IDLE1	Output	PNP Idle control motor
34B	ISC2 (pin 1 on ISC harness)	IDLE3	Output	PNP Idle control motor
35B	ISC1 (pin 4 on ISC harness)	IDLE2	Output	PNP Idle control motor
36B	Fuel Pressure Up solenoid valve (93-96)	IDLE5	Output	Available, switched Ground / +12V, 1.5A max
37B	---	IDLE6	Output	Available, switched +12V/Ground, 1.5A max
38B	---	LS4	Output	Available, switched GND output (1.5A max)
39B	ACIS solenoid – (intake runner length valve)	LS5	Output	PNP for ACIS valve
40B	---	LS3	Output	Available, switched GND output (1.5A max)

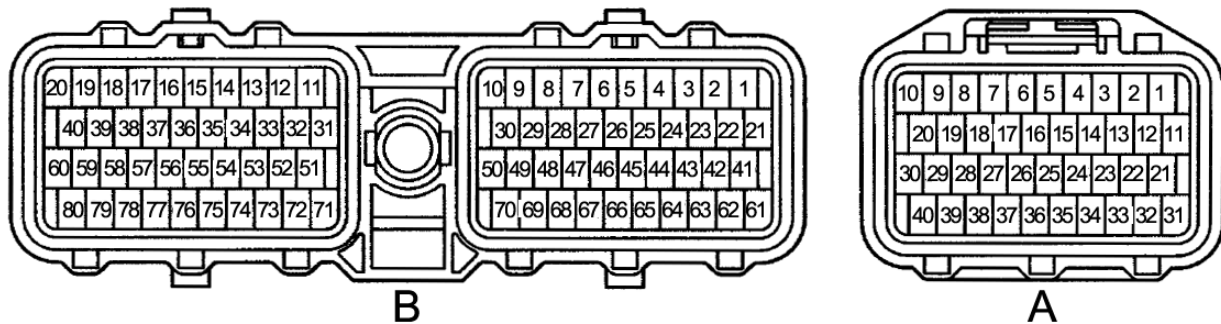

WARNING: pin labeling scheme follows Toyota service manual convention; diagram shows wire side of connector. Pin labels molded into plastic connector may not be accurate, check diagram carefully.

Connection Diagram for EMS P/N 30-6101

41B	5V Reference	+5V Sensor	Output	Dedicated
42B	---	---	---	Not Used
43B	TPS signal input (VTA1)	TPS	Input	Dedicated, 2.2kΩ pull-up resistor to 5V
44B	Coolant Sensor Input	Coolant	Input	Dedicated, 2.2kΩ pull-up resistor to 5V
45B	Air Temp Sensor	Air Temp	Input	Dedicated
46B	EGR gas Temp Sensor	---	---	Not Used
47B	OX2 (rear O2 sensor)	O2 #1	Input	Dedicated, 0-5V signal
48B	OX1 (front O2 sensor)	O2 #2	Input	Dedicated, 0-5V signal
49B	Rear Knock Sensor	Knock 2	Input	Dedicated, software knock filter
50B	Front Knock Sensor	Knock 1	Input	Dedicated, software knock filter
51B	---	---	---	Not Used
52B	---	Coil 6	Output	Avail. Coil6 output, 0-5V falling edge trigger
53B	---	Coil 5	Output	Avail. Coil5 output, 0-5V falling edge trigger
54B	---	Coil 4	Output	Avail. Coil4 output, 0-5V falling edge trigger
55B	---	Coil 3	Output	Avail. Coil3 output, 0-5V falling edge trigger
56B	---	Coil 2	Output	Avail. Coil2 output, 0-5V falling edge trigger
57B	Igniter Control (IGT)	Coil 1	Output	PnP Coil1 output, 0-5V falling edge trigger
58B	Igniter return (IGF) to ECU	---	---	Not Used
59B	---	LS11	Output	Available Switched Ground 1.5amp max
60B	---	PW2	Output	Available boost control solenoid output
61B	---	---	---	Not Used
62B	---	MAP	Input	Dedicated
63B	---	---	---	Not Used
64B	Idle1 Sw from TPS	---	---	Not Used
65B	Sensor Ground	Sensor Ground	Output	Dedicated, Sensors only
66B	VG signal for Airflow meter	MAF	Input	Available 0 to 5v input, 100k pull-up to 5V
67B	---	EGT 4	Input	Jumper: 0-5V, thermistor or EGT pull up
68B	---	LS9	Output	Available Switched Ground 1.5amp max
69B	E1- Ground	Power Ground	Both	Dedicated
70B	---	Injector 7	Output	Available P&H Injector driver 4A/1A
71B	Ox 1 Heater Ground (96-97)	LS12	Output	Available Switched Ground 1.5amp max
72B	HT2 – rear O2 heater control (CA only)	LS2	Output	Available Switched Ground 1.5amp max
73B	HT1 – front O2 heater control (CA only) / Fuel Pressure up solenoid (1997)	LS1	Output	Available Switched Ground 1.5amp max
74B	EVAP Solenoid	Injector 9	Output	Available P&H Injector driver 4A/1A
75B	EGR Solenoid	Injector 10	Output	Available P&H Injector driver 4A/1A
76B	Park / Neutral position switch (AT only)	ATPNP (Gear)	Input	Reserved for future use
77B	Cranking signal input (12V)	---	---	Not Used
78B	Chassis Ground - EO3 (96-97)	Power Ground	Both	Dedicated
79B	Chassis Ground – EO2	Power Ground	Both	Dedicated
80B	Chassis Ground – EO1	Power Ground	Both	Dedicated

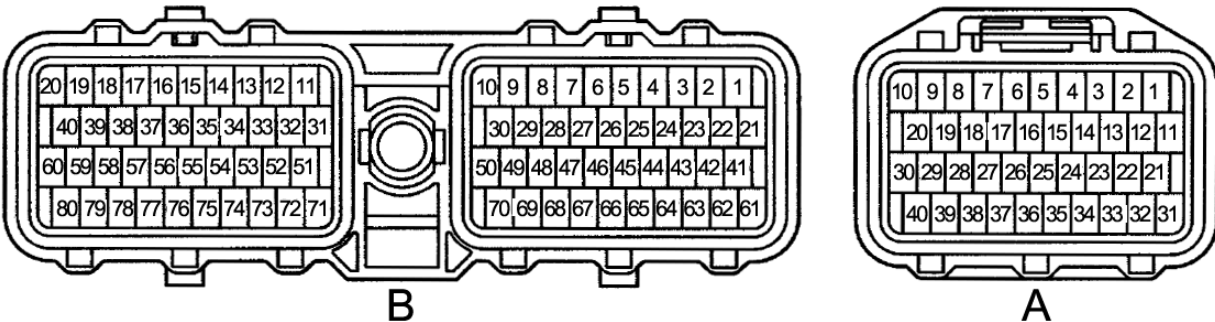

WARNING: pin labeling scheme follows Toyota service manual convention; diagram shows wire side of connector. Pin labels molded into plastic connector may not be accurate, check diagram carefully.

30-1101 (Series 1) vs 30-6101 (Series 2) Supra / SC300 / GS300 EMS pin differences:

The EMS functions assigned to certain pins have been changed and no longer match the 30-1101 EMS. Unless otherwise noted, the following pins and functions will need to be manually reconfigured after using AEMTuner to convert a V1.19 (30-1101, Series 1 EMS) calibration for use with the 30-6101 Series 2 hardware.

Pin	93-97 Supra harness destination	30-1101 function	30-6100 function	Notes
3A	Kickdown switch	--	Switch 3	
4A	Brake switch input	--	Switch 6	
11A	--	--	CAN1L	
12A	OD1 to cruise control ECU (AT only)	--	CAN1H	
17A	TT for datalink connector	Injector 10i	Injector 12	Inj12 controlled independently of inj10
19A	TE2 for datalink connector	Injector 9i	Injector 11	Inj11 controlled independently of inj9
20A	TE1 for datalink connector	PW1	--	PW1 not available
22A	Fuel Pump ctrl	Coil 4	Coil 8	Coil 4 reassigned to spare ignition out, Coil 8 must be used to operate Fuel Pump
24A	Main Relay ctrl	Coil 5	HS2	Coil 5 reassigned to spare ignition out, HS2 must be used to operate Main Relay
25A	Manual indicator light (A/T)	FM	Coil 7	FM output not available with Series 2 firmware, use Coil 7
29A	--	--	Baro Volts (ADCR12)	Available 0-5V input... can be assigned to external baro pressure sensor
30A	Sub O2 signal (CA only)	HS2	--	HS2 used for main relay control
36A	Sub O2 sensor heater control	--	Injector 8	Injector 8 no longer used for A/T control, signal has been moved to empty pin
37A	--	PW2	--	PW2 available on pin 60B only
38A	NEO to trac ECU	--	LS7 (tacho)	
5B	Cam sensor NE2 ground	TGND	--	G2 not used
12B	AT sol 5	Idle 7	PW1	Reserved for future use
13B	AT sol 4	Injector 8	PW4	Injector 8 available on pin 36A
14B	AT sol 3	Idle 5	PW3	Reserved for future use
52B	---	Coil1 (waste spark)	Coil 6	
53B	---	Coil 2 (waste spark)	Coil 5	
54B	---	Coil 3 (waste spark)	Coil 4	

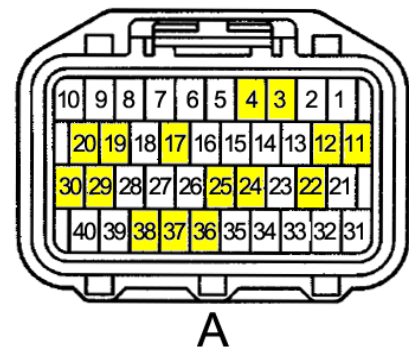
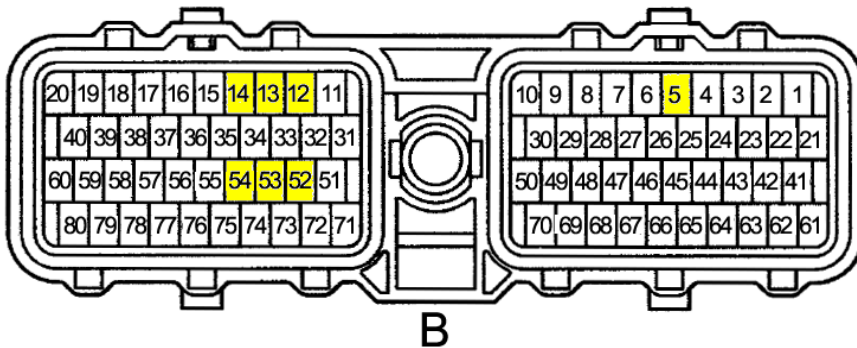

Electronics Warranty

Advanced Engine Management Inc. warrants to the consumer that all AEM Electronics products will be free from defects in material and workmanship for a period of twelve months from date of the original purchase. Products that fail within this 12-month warranty period will be repaired or replaced when determined by AEM that the product failed due to defects in material or workmanship. This warranty is limited to the repair or replacement of the AEM part. In no event shall this warranty exceed the original purchase price of the AEM part nor shall AEM be responsible for special, incidental or consequential damages or cost incurred due to the failure of this product. Warranty claims to AEM must be transportation prepaid and accompanied with dated proof of purchase. This warranty applies only to the original purchaser of product and is non-transferable. All implied warranties shall be limited in duration to the said 12-month warranty period. Improper use or installation, accident, abuse, unauthorized repairs or alterations voids this warranty. AEM disclaims any liability for consequential damages due to breach of any written or implied warranty on all products manufactured by AEM. Warranty returns will only be accepted by AEM when accompanied by a valid Return Merchandise Authorization (RMA) number. Product must be received by AEM within 30 days of the date the RMA is issued.

Please note that before AEM can issue an RMA for any electronic product, it is first necessary for the installer or end user to contact the tech line at 1-800-423-0046 to discuss the problem. Most issues can be resolved over the phone. Under no circumstances should a system be returned or a RMA requested before the above process transpires.

AEM will not be responsible for electronic products that are installed incorrectly, installed in a non approved application, misused, or tampered with.

Any AEM electronics product can be returned for repair if it is out of the warranty period. There is a minimum charge of \$50.00 for inspection and diagnosis of AEM electronic parts. Parts used in the repair of AEM electronic components will be extra. AEM will provide an estimate of repairs and receive written or electronic authorization before repairs are made to the product.