

# Instruction Manual



## P/N 30-3500 1993–1998 Toyota Supra MKIV Twin Turbo Manual Transmission Plug & Play Adapter Harness



### STOP!

**THIS PRODUCT HAS LEGAL RESTRICTIONS.**  
**READ THIS BEFORE INSTALLING/USING!**

THIS PRODUCT MAY BE USED SOLELY ON VEHICLES USED IN SANCTIONED COMPETITION WHICH MAY NEVER BE USED UPON A PUBLIC ROAD OR HIGHWAY, UNLESS PERMITTED BY SPECIFIC REGULATORY EXEMPTION. (VISIT THE "EMISSIONS" PAGE AT [HTTP://WWW.SEMASAN.COM/EMISSIONS](http://www.semasan.com/EMISSIONS) FOR STATE BY STATE DETAILS.)

IT IS THE RESPONSIBILITY OF THE INSTALLER AND/OR USER OF THIS PRODUCT TO ENSURE THAT IT IS USED IN COMPLIANCE WITH ALL APPLICABLE LAWS AND REGULATIONS. IF THIS PRODUCT WAS PURCHASED IN ERROR, DO NOT INSTALL AND/OR USE IT. THE PURCHASER MUST ARRANGE TO RETURN THE PRODUCT FOR A FULL REFUND.

THIS POLICY ONLY APPLIES TO INSTALLERS AND/OR USERS WHO ARE LOCATED IN THE UNITED STATES; HOWEVER CUSTOMERS WHO RESIDE IN OTHER COUNTRIES SHOULD ACT IN ACCORDANCE WITH THEIR LOCAL LAWS AND REGULATIONS.

**WARNING:** This installation is not for the tuning novice! Use this system with **EXTREME** caution! The AEM Infinity Programmable EMS allows for total flexibility in engine tuning. Misuse or improper tuning of this product can destroy your engine! If you are not well versed in engine dynamics and the tuning of engine management systems **DO NOT** attempt the installation. Refer the installation to an AEM-trained tuning shop or call 800-423-0046 for technical assistance.

**NOTE:** All supplied AEM calibrations, Wizards and other tuning information are offered as potential starting points only. **IT IS THE RESPONSIBILITY OF THE ENGINE TUNER TO ULTIMATELY CONFIRM IF THE CALIBRATION IS SAFE FOR ITS INTENDED USE.** AEM holds no responsibility for any engine damage that results from the misuse or mistuning of this product!

AEM Performance Electronics  
AEM Performance Electronics, 2205 126th Street Unit A, Hawthorne, CA 90250  
Phone: (310) 484-2322 Fax: (310) 484-0152  
<http://www.aemelectronics.com>  
Instruction Part Number: 10-3500  
Document Build 4/2/2015

## OVERVIEW

The 30-3500 AEM Infinity Adapter Kit is designed for the 1993–1998 Toyota Supra MKIV Twin Turbo (manual transmission). This is a true standalone system that eliminates the use of the factory ECU. The use of this adapter makes the kit “plug and play” so no cutting or splicing wires is necessary. The base configuration files available for the Infinity EMS are starting points only and will need to be modified for every specific application.

The available AEM Infinity EMS part numbers for this adapter kit are:

- 30-7100 INFINITY-8
- 30-7101 INFINITY-10

## GETTING STARTED

Refer to the **10-7100 for EMS 30-7100 Infinity Quick Start Guide** for additional information on getting the engine started with the Infinity EMS. Toyota Supra MKIV Twin Turbo base sessions are located in C:\Documents\AEM\Infinity Tuner\Sessions\Base Sessions

## DOWNLOADABLE FILES

Files can be downloaded from [www.aeminfinity.com](http://www.aeminfinity.com). An experienced tuner must be available to configure and manipulate the data before driving can commence. The Quick Start Guide and Full Manual describe the steps for logging in and registering at [www.aeminfinity.com](http://www.aeminfinity.com). These documents are available for download in the Support section of the AEM Electronics website: <http://www.aemelectronics.com/products/support/instructions>

### Downloadable files for 1993–1998 MKIV Toyota Supra Twin Turbo

- 7100-XXXX-62 Infinity-10 (XXXX = serial number)
- 7101-XXXX-63 Infinity-8 (XXXX = serial number)

## OPTIONS

### **30-3600 UEGO Wideband O2 Sensor Extension Harness**

Extension harness to connect AEM UEGO Wideband O2 sensor to 6-pin Deutsch

### **30-3601 IP67 Comms Cable**

### **30-3602 IP67 Logging Cable**

USB A-to-A extension cable: 39" long with right angled connector and bayonet style lock

## INFINITY CONNECTORS

The AEM Infinity EMS uses the MX123 Sealed Connection System from Molex. AEM strongly recommends that users become familiar with the proper tools and procedures for working with these high density connectors before attempting any modifications. The entire Molex MX123 User Manual can be downloaded direct from Molex at:

[http://www.molex.com/mx\\_upload/family//MX123UserManual.pdf](http://www.molex.com/mx_upload/family//MX123UserManual.pdf)



## INFINITY ADAPTER HARNESS

Included with the 1993–1998 Toyota Supra MKIV Twin Turbo kit is an adapter harness. This is used to make the connection between the AEM Infinity EMS and the Toyota wiring harness plug and play. This is depicted below with the 73-pin and 56-pin connectors and the Toyota header. There are also a few other integrated connectors.



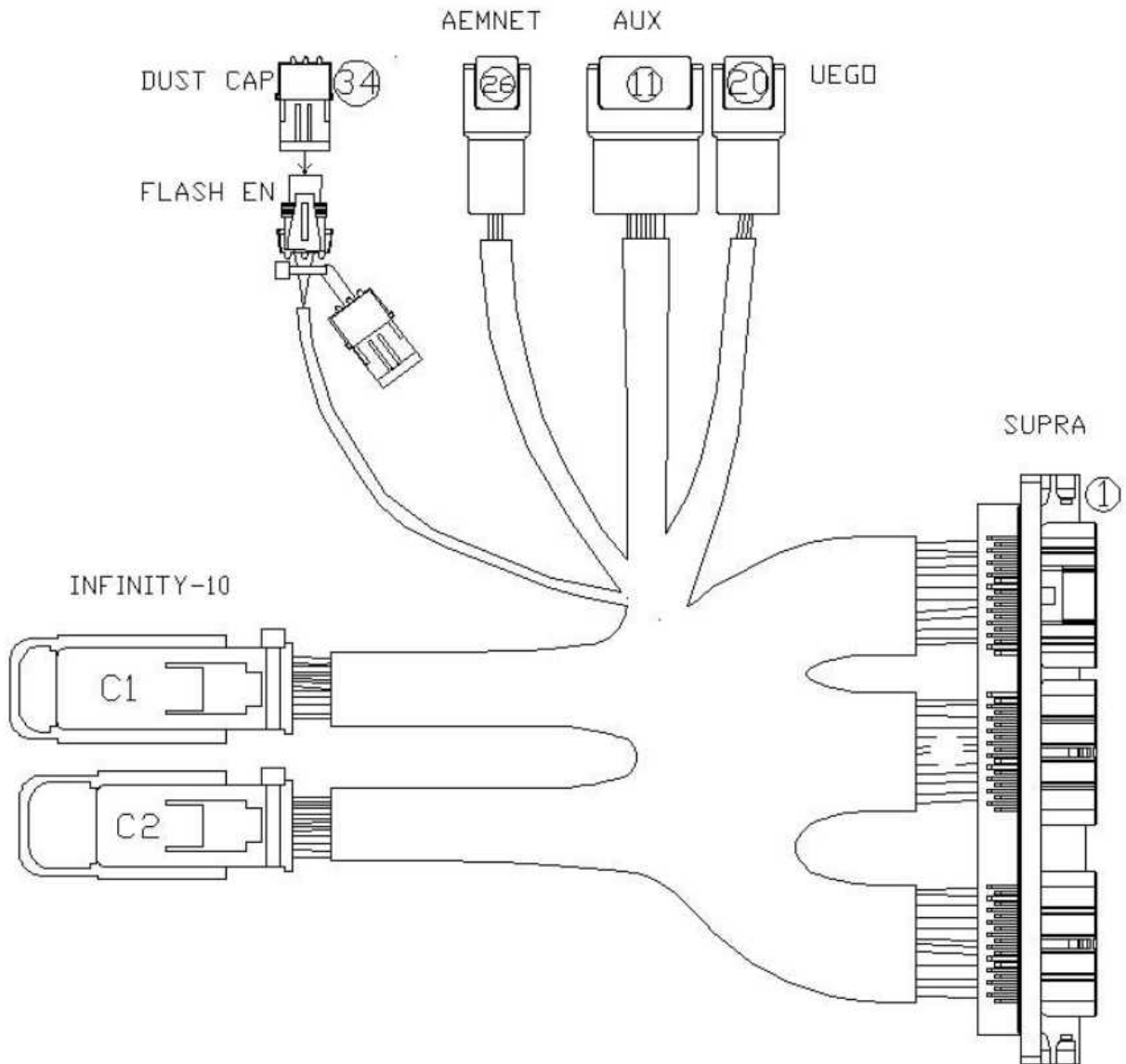

## ECU SETUP WIZARD

### Important Application Specific Settings

### Engine

In the Wizard Engine tab confirm the following:

<i>Number of Cylinders</i>	= 6
<i>Engine Cycle Type</i>	= 4 Stroke
<i>Ignition Type</i>	= Sequential (Coil On Plug)
<i>Firing Order</i>	= 1-5-3-6-2-4

## Cam/Crank

In the Wizard Cam/Crank tab confirm the following:

*Toyota Supra (1993–1998 Turbo)*

Open the Advanced Setup tab and set the following:

*Crank Noise Cancellation* = 70  
*Cam 1 Noise Cancellation* = 70

Add the 1-Axis Lookup Table *VR\_PwmDuty [%]* to your layout. Set the following:

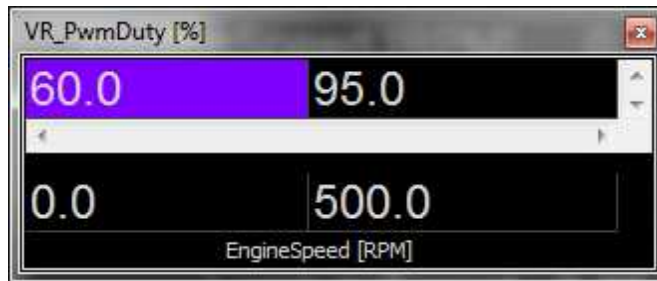

## Ignition Sync

Add a text grid control to your layout and select the following channels. Make sure their values match the settings below for initial timing sync.

*TrigOffset [degBTDC]* = 23.00  
*CamSyncAdjustment* = 11.00

See QuickStart Guide section **Setup: Ignition Sync** for instructions on timing sync.

## Idle Stepper Max Steps

Go to Setup Wizard Idle page and confirm the following:

*Idle Stepper Max Steps* = 132

## AC Input Switch

Go to Setup Wizard Input Function Assignment page and confirm the following:

*AC Input Switch Setup* = Analog17[V]

## IDLE AIR CONTROL VALVE REQUIREMENTS

Many Toyota, Mitsubishi, and other vehicles use an Idle Air Control Valve with a Unipolar Stepper Motor (6-pin connector) and **MUST** be modified. See instructions below. A Bipolar Stepper Motor (e.g., GM) will have a 4-pin connector and **DOES NOT** need to be modified.

\*This info does not apply to vehicles that utilize IACV solenoids.



The 2 center pins (Black-Red wires) supply 12V power to the stepper motor in the factory setup, however these pins **MUST BE DISCONNECTED** before powering the AEM Infinity ECU.



Step 1: Disconnect connector from IACV housing and gently remove the retainer from the connector.



Step 2: Use a small flat-blade screwdriver/pick to move the terminal locks while pulling the Black-Red wires out from the backside of the connector.





Step 3: Use heat shrink to insulate both 12V wires, and then zip-tie the insulated wires to a nearby loom.



Step 4: Reinstall the retainer, and then plug the connector back into the IACV.

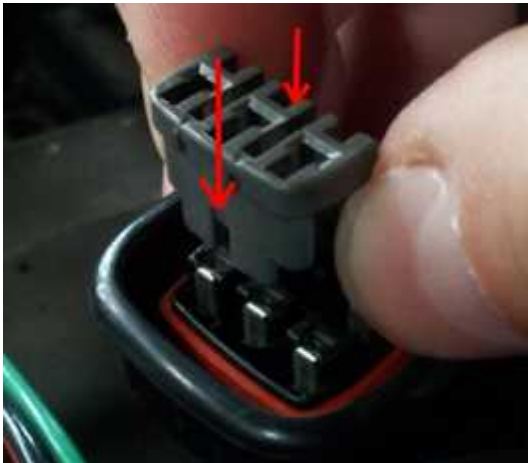



## MAIN RELAY/FUEL PUMP SCHEMATIC

The 1993–1998 Toyota Supra Infinity patch harness requires a harness relay and fuel pump control to be wired exactly as pictured below. Failure to do so may result in an unresponsive ECU and/or a no-start condition.

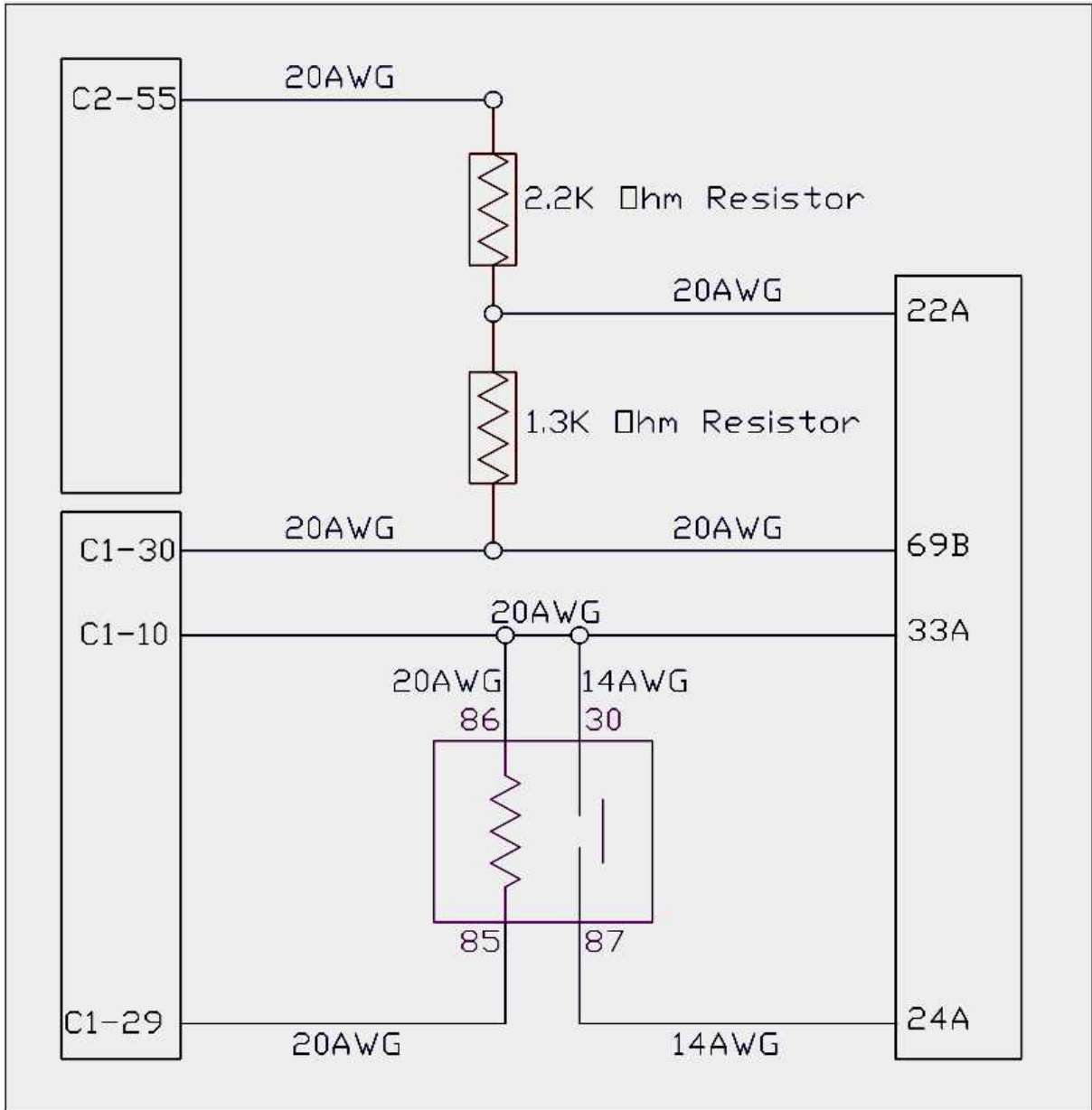

## ECU COVER MODIFICATIONS

It is recommend that the OEM ECU cover panel be modified and reinstalled with the AEM Infinity EMS when utilizing the mounting bracket. Failure to properly clearance and reinstall this panel (**Toyota PN#55199-14020**) could potentially result in damage to the ECU, adapter harness, ECU connectors and/ or USB cables and connectors.

Please note clearance modifications below. These modifications should be performed with a die grinder, 90-degree sander, or plastic shears.

Step 1: Remove the four ribs located near the center of the cover as highlighted below.

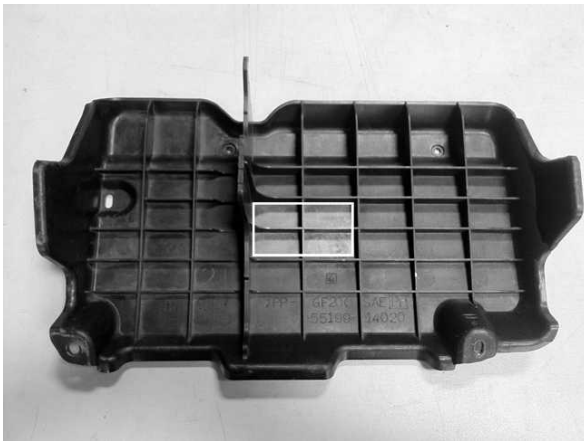

Step 2: Trim the center support leg as outlined. Test fit, note, and trim any additional areas required.



## INFINITY EMS INSTALLATION

### Step 1

Disconnect battery's negative cable.

### Step 2

Locate factory Engine Control Unit (ECU). Most ECU's are located in the passenger kick panel, behind the center console, or in the engine bay.



### Step 3

Unplug factory harness plugs at ECU and remove factory ECU.

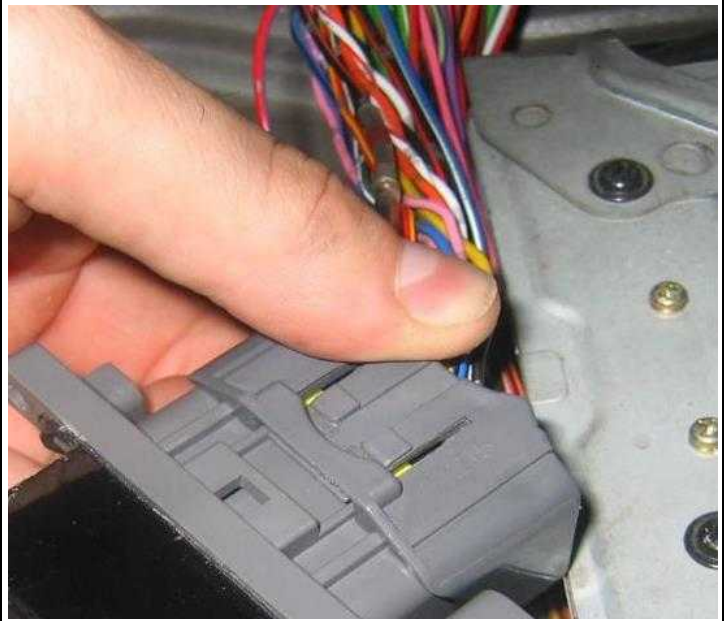
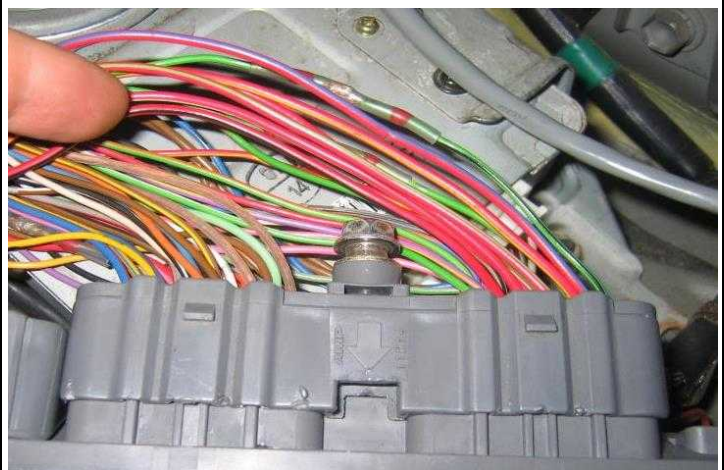

## Step 4

Plug factory harness plugs into AEM Infinity Adapter Harness.





## Step 5

Mount the Infinity ECU and connect Infinity connectors and USB cables.



## Step 6

Run the USB cables to an easily accessible location.

## Step 7

Reconnect the battery's negative cable.



## PINOOTS

### Infinity Pinouts

Dedicated	Dedicated and not reconfigurable
Assigned	Assigned but reconfigurable
Available	Available for user setup
Not Applicable	Not used in this configuration
Required	Required for proper function

Infinity Pin	Hardware Reference	7100-XXXX-62 7101-XXXX-63 Function	Hardware Specification	Notes
C1-1	LowsideSwitch_4	A/C Relay Control	Lowside switch, 4A max, NO internal flyback diode.	See "LowSide Assignment Tables" for output assignment.
C1-2	LowsideSwitch_5	LS5	Lowside switch, 4A max with internal flyback diode. Inductive load should NOT have full time power.	See Setup Wizard Page "LowSide Assignment Tables" for output assignment and 2D table "LS5_Duty [%]" for activation.
C1-3	LowsideSwitch_6	LS6	Lowside switch, 4A max with internal flyback diode. Inductive load should NOT have full time power.	See Setup Wizard Page "LowSide Assignment Tables" for output assignment and 2D table "LS6_Duty [%]" for activation.
C1-4	UEGO 1 Heat	UEGO 1 Heat	Bosch UEGO controller	Lowside switch for UEGO heater control. Connect to pin 4 of Bosch UEGO sensor. NOTE that pin 3 of the Sensor is heater (+) and must be power by a fused/switched 12V supply.
C1-5	UEGO 1 IA	UEGO 1 IA		Trim Current signal. Connect to pin 2 of Bosch UEGO sensor.
C1-6	UEGO 1 IP	UEGO 1 IP		Pumping Current signal. Connect to pin 6 of Bosch UEGO sensor.
C1-7	UEGO 1 UN	UEGO 1 UN		Nernst Voltage signal. Connect to pin 1 of Bosch UEGO sensor.
C1-8	UEGO 1 VM	UEGO 1 VM		Virtual Ground signal. Connect to pin 5 of Bosch UEGO sensor.
C1-9	Flash_Enable	Flash Enable	10K pulldown	Not usually needed for automatic firmware updates through Infinity Tuner. If connection errors occur during update, connect 12 volts to this pin before proceeding with upgrade. Disconnect the 12 volts signal after the update.

Infinity Pin	Hardware Reference	7100-XXXX-62 7101-XXXX-63 Function	Hardware Specification	Notes
C1-10	+12V_R8C_CPU	Battery Perm Power	Dedicated power management CPU	Full time battery power. MUST be powered before the ignition switch input is triggered. (See C1-65.)
C1-11	Coil 4	Coil 4	25 mA max source current	0-5V Falling edge fire. DO NOT connect directly to coil primary. Must use an ignitor OR CDI that accepts a FALLING edge fire signal.
C1-12	Coil 3	Coil 3	25 mA max source current	0-5V Falling edge fire. DO NOT connect directly to coil primary. Must use an ignitor OR CDI that accepts a FALLING edge fire signal.
C1-13	Coil 2	Coil 2	25 mA max source current	0-5V Falling edge fire. DO NOT connect directly to coil primary. Must use an ignitor OR CDI that accepts a FALLING edge fire signal.
C1-14	Coil 1	Coil 1	25 mA max source current	0-5V Falling edge fire. DO NOT connect directly to coil primary. Must use an ignitor OR CDI that accepts a FALLING edge fire signal.
C1-15	Coil 6	Coil 6	25 mA max source current	0-5V Falling edge fire. DO NOT connect directly to coil primary. Must use an ignitor OR CDI that accepts a FALLING edge fire signal.
C1-16	Coil 5	Coil 5	25 mA max source current	0-5V Falling edge fire. DO NOT connect directly to coil primary. Must use an ignitor OR CDI that accepts a FALLING edge fire signal.
C1-17	LowsideSwitch_2	Coolant Fan 1 Control	Lowside switch, 4A max, NO internal fly back diode.	See "LowSide Assignment Tables" for output assignment.
C1-18	LowsideSwitch_3	MIL Output	Lowside switch, 4A max with internal flyback diode. Inductive load should NOT have full time power.	See Wizard page "LowSide Assignment Tables" for output assignment. MIL Activates when any of the following flags are true: ErrorAirTemp, ErrorBaro, ErrorCoolantTemp, ErrorEBP, ErrorFuelPressure, UEGO_0_Diag_error, UEGO_1_Diag_error, ErrorMAFAnalog, ErrorMAFDigital, ErrorMAP, ErrorOilPressure, ErrorThrottle.
C1-19	AGND_1	Sensor Ground	Dedicated analog ground	Analog 0-5V sensor ground

Infinity Pin	Hardware Reference	7100-XXXX-62 7101-XXXX-63 Function	Hardware Specification	Notes
C1-20	AGND_1	Sensor Ground	Dedicated analog ground	Analog 0–5V sensor ground
C1-21	Crankshaft Position Sensor Hall	Crankshaft Position Sensor Hall	10K pullup to 12V. Will work with ground or floating switches.	See Setup Wizard page Cam/Crank for options.
C1-22	Camshaft Position Sensor 1 Hall	Camshaft Position Sensor 1 Hall	10K pullup to 12V. Will work with ground or floating switches.	See Setup Wizard page Cam/Crank for options.
C1-23	Digital_In_2	Camshaft Position Sensor 2 Hall	10K pullup to 12V. Will work with ground or floating switches.	See Setup Wizard page Cam/Crank for options.
C1-24	Digital_In_3	Turbo Speed Hz	10K pullup to 12V. Will work with ground or floating switches.	See Setup Wizard page Input Function Assignment for calibration constant. TurboSpeed [RPM] = Turbo [Hz] * Turbo Speed Calibration.
C1-25	Digital_In_4	Vehicle Speed Sensor	10K pullup to 12V. Will work with ground or floating switches.	See Setup Wizard page Input Function Assignment for calibration constant.
C1-26	Digital_In_5	Flex Fuel	10K pullup to 12V. Will work with ground or floating switches.	See channel FlexDigitalIn [Hz] for raw frequency input data.
C1-27	Knock Sensor 1	Knock Sensor 1	Dedicated knock signal processor	See Setup Wizard page Knock Setup for options.
C1-28	Knock Sensor 2	Knock Sensor 2	Dedicated knock signal processor	See Setup Wizard page Knock Setup for options.
C1-29	+12V_Relay_Control	+12V Relay Control	0.7A max ground sink for external relay control	Will activate at key on and at key off according to the configuration settings.
C1-30	Power Ground	Ground	Power Ground	Connect directly to battery ground.
C1-31	CANL_Aout	AEMNet CANL	Dedicated High Speed CAN Transceiver	Recommend twisted pair (one twist per 2") with terminating resistor. Contact AEM for additional information.
C1-32	CANH_Aout	AEMNet CANH	Dedicated High Speed CAN Transceiver	Recommend twisted pair (one twist per 2") with terminating resistor. Contact AEM for additional information.
C1-33	LowsideSwitch_1	Boost Control	Lowside switch, 4A max with internal flyback diode. Inductive load should NOT have full time power.	See Setup Wizard page Boost Control for options. Monitor BoostControl [%] channel for output state.
C1-34	Lowside Fuel Pump drive	Fuel Pump	Lowside switch, 4A max, NO internal flyback diode.	Switched ground. Will prime for 2 seconds at key on and activate if RPM > 0.

Infinity Pin	Hardware Reference	7100-XXXX-62 7101-XXXX-63 Function	Hardware Specification	Notes
C1-35	Analog_In_7	Throttle Position Sensor	12 bit A/D, 100K pullup to 5V	0–5V analog signal. Use +5V Out pins as power supply and Sensor Ground pins as the low reference. Do not connect signals referenced to +12V as this can permanently damage the ECU. See the Setup Wizard Set Throttle Range page for automatic min/max calibration. Monitor the Throttle [%] channel. Also DB1_TPSA [%] for DBW applications.
C1-36	Analog_In_8	MAP Sensor	12 bit A/D, 100K pullup to 5V	0–5V analog signal. Use +5V Out pins as power supply and Sensor Ground pins as the low reference. Do not connect signals referenced to +12V as this can permanently damage the ECU. See the Setup Wizard Set Manifold Pressure page for setup and calibration. Monitor the MAP [kPa] channel.
C1-37	Analog_In_9	Fuel Pressure	12 bit A/D, 100K pullup to 5V	0–5V analog signal. Use +5V Out pins as power supply and Sensor Ground pins as the low reference. Do not connect signals referenced to +12V as this can permanently damage the ECU. See the Setup Wizard Fuel Pressure page for setup and calibration. Monitor the FuelPressure [psig] channel.
C1-38	Analog_In_10	Baro Sensor	12 bit A/D, 100K pullup to 5V	0–5V analog signal. Use +5V Out pins as power supply and Sensor Ground pins as the low reference. Do not connect signals referenced to +12V as this can permanently damage the ECU. See the Setup Wizard Barometric Pressure page for setup and calibration. Monitor the BaroPress [kPa] channel.
C1-39	Analog_In_11	Shift Switch Input	12 bit A/D, 100K pullup to 5V	0–5V analog signal. Use +5V Out pins as power supply and Sensor Ground pins as the low reference. Do not connect signals referenced to +12V as this can permanently damage the ECU. See the 1D lookup table 'ShiftSwitch' for setup. Also assignable to multiple functions. See Setup Wizard for details.
C1-40	Analog_In_12	Mode Switch	12 bit A/D, 100K pullup to 5V	0–5V analog signal. Use +5V Out pins as power supply and Sensor Ground pins as the low reference. Do not connect signals referenced to +12V as this can permanently damage the ECU. See the 1D lookup table 'ModeSwitch' for input state. A multi-position rotary switch such as AEM P/N 30-2056 is recommended. Also assignable to multiple functions. See Setup Wizard for details.

Infinity Pin	Hardware Reference	7100-XXXX-62 7101-XXXX-63 Function	Hardware Specification	Notes
C1-41	+5V_Out_1	+5V Out	Regulated, fused +5V supply for sensor power	Analog sensor power
C1-42	+5V_Out_1	+5V Out	Regulated, fused +5V supply for sensor power	Analog sensor power
C1-43	HighsideSwitch_1	HS1 (switched 12V)	0.7A max, High Side Solid State Relay	See Setup Wizard page 'HighSide Assignment Tables' for configuration options. See 2D lookup table 'HS1_Table' for activation settings.
C1-44	HighsideSwitch_0	VTEC	0.7A max, High Side Solid State Relay	See Setup Wizard page 'HighSide Assignment Tables' for configuration options. See 2D lookup table 'HS0_Table' for activation settings. See Setup Wizard page 'VTEC' for default activation criteria.
C1-45	Crankshaft Position Sensor VR+	Crankshaft Position Sensor VR+	Differential Variable Reluctance Zero Cross Detection	See Setup Wizard page Cam/Crank for options.
C1-46	Crankshaft Position Sensor VR-	Crankshaft Position Sensor VR-		See Setup Wizard page Cam/Crank for options.
C1-47	Camshaft Position Sensor 1 VR-	Camshaft Position Sensor 1 VR-	Differential Variable Reluctance Zero Cross Detection	See Setup Wizard page Cam/Crank for options.
C1-48	Camshaft Position Sensor 1 VR+	Camshaft Position Sensor 1 VR+		See Setup Wizard page Cam/Crank for options.
C1-49	VR+_In_2	Non Driven Left Wheel Speed Sensor +	Differential Variable Reluctance Zero Cross Detection	See Non Driven Wheel Speed Calibration in the Setup Wizard Input Function Assignment page.
C1-50	VR-_In_2	Non Driven Left Wheel Speed Sensor -		
C1-51	VR-_In_3	Driven Left Wheel Speed Sensor -	Differential Variable Reluctance Zero Cross Detection	See Driven Wheel Speed Calibration in the Setup Wizard Input Function Assignment page.
C1-52	VR+_In_3	Driven Left Wheel Speed Sensor +		
C1-53	DBW1 Motor -	DBW Motor Control Close	5.0A max Throttle Control Hbridge Drive	+12V to close
C1-54	DBW1 Motor +	DBW Motor Control Open	5.0A max Throttle Control Hbridge Drive	+12V to open
C1-55	Power Ground	Ground	Power Ground	Connect directly to battery ground.
C1-56	Injector 6	Injector 6	Saturated or peak and hold, 3A max continuous	Injector 6

Infinity Pin	Hardware Reference	7100-XXXX-62 7101-XXXX-63 Function	Hardware Specification	Notes
C1-57	Injector 5	Injector 5	Saturated or peak and hold, 3A max continuous	Injector 5
C1-58	Injector 4	Injector 4	Saturated or peak and hold, 3A max continuous	Injector 4
C1-59	Injector 3	Injector 3	Saturated or peak and hold, 3A max continuous	Injector 3
C1-60	Power Ground	Ground	Power Ground	Connect directly to battery ground.
C1-61	+12V	+12V In	12 volt power from relay	12 volt power from relay. Relay must be controlled by +12V Relay Control signal, pin C1-29 above.
C1-62	Injector 2	Injector 2	Saturated or peak and hold, 3A max continuous	Injector 2
C1-63	Injector 1	Injector 1	Saturated or peak and hold, 3A max continuous	Injector 1
C1-64	+12V	+12V In	12 volt power from relay	12 volt power from relay. Relay must be controlled by +12V Relay Control signal pin C1-29 above.
C1-65	+12V_SW	Ignition Switch	10K pulldown	Full time battery power must be available at C1-10 before this input is triggered.
C1-66	Analog_In_Temp_1	Coolant Temp Sensor	12 bit A/D, 2.49K pullup to 5V	See "Coolant Temperature" Setup Wizard for selection.
C1-67	Analog_In_Temp_2	Intake Air Temperature	12 bit A/D, 2.49K pullup to 5V	See "Air Temperature" Setup Wizard for selection.
C1-68	Harness_Analog_In_Temp_3	Oil Temperature Sensor	12 bit A/D, 2.49K pullup to 5V	See 1D table OilTempCal table for calibration data and OilTemp [C] for channel data.
C1-69	Stepper_2A	Stepper 2A	Automotive, Programmable Stepper Driver, up to 28V and $\pm 1.4A$	Be sure that each internal coil of the stepper motor is properly paired with the 1A/1B and 2A/2B ECU outputs. Supports Bi-Polar stepper motors only.
C1-70	Stepper_1A	Stepper 1A	Automotive, Programmable Stepper Driver, up to 28V and $\pm 1.4A$	Be sure that each internal coil of the stepper motor is properly paired with the 1A/1B and 2A/2B ECU outputs. Supports Bi-Polar stepper motors only.
C1-71	Stepper_2B	Stepper 2B	Automotive, Programmable Stepper Driver, up to 28V and $\pm 1.4A$	Be sure that each internal coil of the stepper motor is properly paired with the 1A/1B and 2A/2B ECU outputs. Supports Bi-Polar stepper motors only.
C1-72	Stepper_1B	Stepper 1B	Automotive, Programmable Stepper Driver, up to 28V and $\pm 1.4A$	Be sure that each internal coil of the stepper motor is properly paired with the 1A/1B and 2A/2B ECU outputs. Supports Bi-Polar stepper motors only.
C1-73	Power Ground	Ground	Power Ground	Connect directly to battery ground.



Infinity Pin	Hardware Reference	7100-XXXX-62 7101-XXXX-63 Function	Hardware Specification	Notes
C2-1	DBW2 Motor +	DBW Motor Control Open	5.0A max Throttle Control Hbridge Drive	+12V to open
C2-2	DBW2 Motor -	DBW Motor Control Close	5.0A max Throttle Control Hbridge Drive	+12V to close
C2-3	Power Ground	Ground	Power Ground	Connect directly to battery ground.
C2-4	Injector 7	Injector 7	Saturated or peak and hold, 3A max continuous	Injector 7
C2-5	Injector 8	Injector 8	Saturated or peak and hold, 3A max continuous	Injector 8
C2-6	Injector 9	Injector 9	Saturated or peak and hold, 3A max continuous	Injector 9
C2-7	Injector 10	Injector 10	Saturated or peak and hold, 3A max continuous	Injector 10
C2-8	Power Ground	Ground	Power Ground	Connect directly to battery ground.
C2-9	+12V	+12V In	12 volt power from relay	12 volt power from relay. Relay must be controlled by +12V Relay Control signal, pin C1-29 above.
C2-10	Injector 11	Injector 11	Saturated or peak and hold, 3A max continuous	Not used
C2-11	Injector 12	Injector 12	Saturated or peak and hold, 3A max continuous	Not used
C2-12	Analog_In_17	A/C Analog Request	12 bit A/D, 100K pullup to 5V	0–5V analog signal. Use +5V Out pins as power supply and Sensor Ground pins as the low reference. Do not connect signals referenced to +12V as this can permanently damage the ECU. See Setup Wizard Input Functions page for input selection. See AC_Request_In 1-axis table for activation logic.
C2-13	Analog_In_18	DBW_APP1 [%]	12 bit A/D, 100K pullup to 5V	0–5V analog signal. Use +5V Out pins as power supply and Sensor Ground pins as the low reference. Do not connect signals referenced to +12V as this can permanently damage the ECU.
C2-14	Analog_In_19	DBW_APP2 [%]	12 bit A/D, 100K pullup to 5V	0–5V analog signal. Use +5V Out pins as power supply and Sensor Ground pins as the low reference. Do not connect signals referenced to +12V as this can permanently damage the ECU.
C2-15	Analog_In_Temp_4	Charge Out Temperature	12 bit A/D, 2.49K pullup to 5V	See ChargeOutTemp [C] table for calibration data and ChargeOutTemp [C] for channel data.

Infinity Pin	Hardware Reference	7100-XXXX-62 7101-XXXX-63 Function	Hardware Specification	Notes
C2-16	Analog_In_Temp_5	Airbox Temperature	12 bit A/D, 2.49K pullup to 5V	See AirboxTemp [C] table for calibration data and AirboxTemp [C] for channel data.
C2-17	Analog_In_Temp_6	Fuel Temperature	12 bit A/D, 2.49K pullup to 5V	See FuelTemp [C] table for calibration data and FuelTemp [C] for channel data.
C2-18	Analog_In_13	Oil Pressure	12 bit A/D, 100K pullup to 5V	0–5V analog signal. Use +5V Out pins as power supply and Sensor Ground pins as the low reference. Do not connect signals referenced to +12V as this can permanently damage the ECU. See Setup Wizard Oil Pressure page for setup options. See OilPressure [psig] for channel data.
C2-19	Analog_In_14	Traction Control Mode / Sensitivity	12 bit A/D, 100K pullup to 5V	0–5V analog signal. Use +5V Out pins as power supply and Sensor Ground pins as the low reference. Do not connect signals referenced to +12V as this can permanently damage the ECU. See the TC_SlipTrgtTrim [MPH] 1-axis table. A multi-position rotary switch such as AEM P/N 30-2056 is recommended.
C2-20	Analog_In_15	Exhaust Back Pressure	12 bit A/D, 100K pullup to 5V	0–5V analog signal. Use +5V Out pins as power supply and Sensor Ground pins as the low reference. Do not connect signals referenced to +12V as this can permanently damage the ECU. See Setup Wizard Exhaust Pressure page for setup options. See EBPRESS [kPa] for channel data.
C2-21	Analog_In_16	DBW1_TPSB [%]	12 bit A/D, 100K pullup to 5V	0–5V analog signal. Use +5V Out pins as power supply and Sensor Ground pins as the low reference. Do not connect signals referenced to +12V as this can permanently damage the ECU.
C2-22	+5V_Out_2	+5V Out	Regulated, fused +5V supply for sensor power	Analog sensor power
C2-23	+5V_Out_2	+5V Out	Regulated, fused +5V supply for sensor power	Analog sensor power
C2-24	+5V_Out_2	+5V Out	Regulated, fused +5V supply for sensor power	Analog sensor power
C2-25	VR+_In_5	Driven Right Wheel Speed Sensor +	Differential Variable Reluctance Zero Cross Detection	See Driven Wheel Speed Calibration in the Setup Wizard Input Function Assignment page.
C2-26	VR-_In_5	Driven Right Wheel Speed Sensor -		
C2-27	VR-_In_4	Non Driven Right Wheel Speed Sensor -	Differential Variable Reluctance Zero Cross Detection	See Non Driven Wheel Speed Calibration in the Setup Wizard Input Function Assignment page.
C2-28	VR+_In_4	Non Driven Right Wheel Speed Sensor +		

Infinity Pin	Hardware Reference	7100-XXXX-62 7101-XXXX-63 Function	Hardware Specification	Notes
C2-29	LowsideSwitch_9	Tachometer	Lowside switch, 4A max with internal flyback diode, 2.2K 12V pullup. Inductive load should NOT have full time power.	See Setup Wizard page Tacho for configuration options.
C2-30	AGND_2	Sensor Ground	Dedicated analog ground	Analog 0–5V sensor ground
C2-31	AGND_2	Sensor Ground	Dedicated analog ground	Analog 0–5V sensor ground
C2-32	AGND_2	Sensor Ground	Dedicated analog ground	Analog 0–5V sensor ground
C2-33	Analog_In_20	Spare Analog Input	12 bit A/D, 100K pullup to 5V	0–5V analog signal. Use +5V Out pins as power supply and Sensor Ground pins as the low reference. Do not connect signals referenced to +12V as this can permanently damage the ECU.
C2-34	Analog_In_21	3 Step Enable Switch	12 bit A/D, 100K pullup to 5V	0–5V analog signal. Use +5V Out pins as power supply and Sensor Ground pins as the low reference. Do not connect signals referenced to +12V as this can permanently damage the ECU. See 3StepSwitch 1-axis table for setup.
C2-35	Analog_In_22	USB Logging Activate	12 bit A/D, 100K pullup to 5V	0–5V analog signal. Use +5V Out pins as power supply and Sensor Ground pins as the low reference. Do not connect signals referenced to +12V as this can permanently damage the ECU. See USBLoggingRequestIn channel for input state. See Setup Wizard page USB Logging for configuration options.
C2-36	Analog_In_23	Charge Out Pressure	12 bit A/D, 100K pullup to 5V	0–5V analog signal. Use +5V Out pins as power supply and Sensor Ground pins as the low reference. Do not connect signals referenced to +12V as this can permanently damage the ECU. See ChargeOutPress [kPa] channel for input state. See Setup Wizard page Charge Out Pressure for calibration options.
C2-37	Digital_In_6	Spare Digital Input	No pullup. Will work with TTL signals.	Input can be assigned to different pins. See Setup Wizard page Input Function Assignments for input mapping options.
C2-38	Digital_In_7	Clutch Switch	No pullup. Will work with TTL signals.	See ClutchSwitch 1-axis table for setup options. Input can be assigned to different pins. See Setup Wizard page Input Function Assignments for input mapping options.

Infinity Pin	Hardware Reference	7100-XXXX-62 7101-XXXX-63 Function	Hardware Specification	Notes
C2-39	Power Ground	Ground	Power Ground	Connect directly to battery ground.
C2-40	Power Ground	Ground	Power Ground	Connect directly to battery ground.
C2-41	CanH_Bout	CANH	Dedicated High Speed CAN Transceiver	Not used
C2-42	CanL_Bout	CANL	Dedicated High Speed CAN Transceiver	Not used
C2-43	LowsideSwitch_8	Engine Protect Warning Out	Lowside switch, 4A max with internal flyback diode. Inductive load should NOT have full time power.	Activates if any of the following flags are true: OilPressProtectOut, LeanProtectOut, CoolantProtect. Output can be assigned to other functions. See Setup Wizard page LowSide Assignment Tables for additional options.
C2-44	LowsideSwitch_7	Spare GPO1	Lowside switch, 4A max with internal flyback diode. Inductive load should NOT have full time power.	See Spare GPO1 Basic Setup section of User GPIOs and PWM Setup Wizard page LowSide Assignment Tables for additional options.
C2-45	UEGO 2 VM	UEGO 2 VM	Bosch UEGO Controller	Virtual Ground signal. Connect to pin 5 of Bosch UEGO sensor.
C2-46	UEGO 2 UN	UEGO 2 UN		Nernst Voltage signal. Connect to pin 1 of Bosch UEGO sensor.
C2-47	UEGO 2 IP	UEGO 2 IP		Pumping Current signal. Connect to pin 6 of Bosch UEGO sensor.
C2-48	UEGO 2 IA	UEGO 2 IA		Trim Current signal. Connect to pin 2 of Bosch UEGO sensor.
C2-49	UEGO 2 HEAT	UEGO 2 HEAT		Lowside switch for UEGO heater control. Connect to pin 4 of Bosch UEGO sensor. NOTE that pin 3 of the Sensor is heater (+) and must be power by a fused/switched 12V supply .
C2-50	+12V_R8C_CPU	Battery Perm Power	Dedicated power management CPU	Optional full time battery power. MUST be powered before the ignition switch input is triggered. (See C1-65.)
C2-51	Coil 7	Coil 7	25 mA max source current	0-5V falling edge fire. DO NOT connect directly to coil primary. Must use an ignitor OR CDI that accepts a FALLING edge fire signal.
C2-52	Coil 8	Coil 8	25 mA max source current	0-5V falling edge fire. DO NOT connect directly to coil primary. Must use an ignitor OR CDI that accepts a FALLING edge fire signal.

Infinity Pin	Hardware Reference	7100-XXXX-62 7101-XXXX-63 Function	Hardware Specification	Notes
C2-53	Coil 9	Coil 9	25 mA max source current	0–5V Falling edge fire. DO NOT connect directly to coil primary. Must use an ignitor OR CDI that accepts a FALLING edge fire signal.
C2-54	Coil 10	Coil 10	25 mA max source current	0–5V falling edge fire. DO NOT connect directly to coil primary. Must use an ignitor OR CDI that accepts a FALLING edge fire signal.
C2-55	Highside Fuel Pump switch	Fuel Pump	Highside switch, 0.7A max, Solid State Relay, NO internal fly back diode.	+12V High Side Drive. Will prime for 2 seconds at key on and activate if RPM > 0.
C2-56	Not used	Not used	Not used	Not used

### Aux Connector Pinout

DTM 12 Pin Connector	Infinity-10
1	C1-37, Analog_In_9, Fuel Pressure
2	
3	C2-32, AGND_2, Sensor Ground
4	+5V_Out_1, 5 Volt Sensor Power
5	
6	C1-26, Digital_In_5, Flex Fuel
7	
8	
9	
10	C1-40, Analog_In_12, Mode Switch
11	
12	

### Toyota Pin Numbering

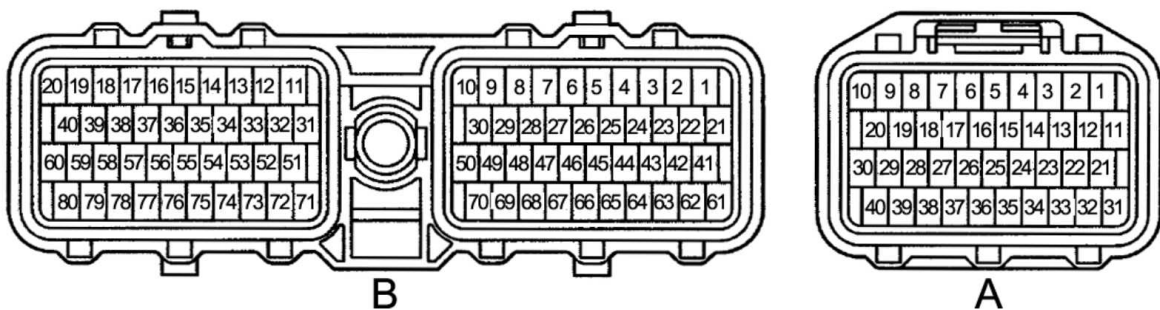

1993–1998 Toyota Supra ECU Connectors Viewed from Wire Side

## Infinity Pin Numbering

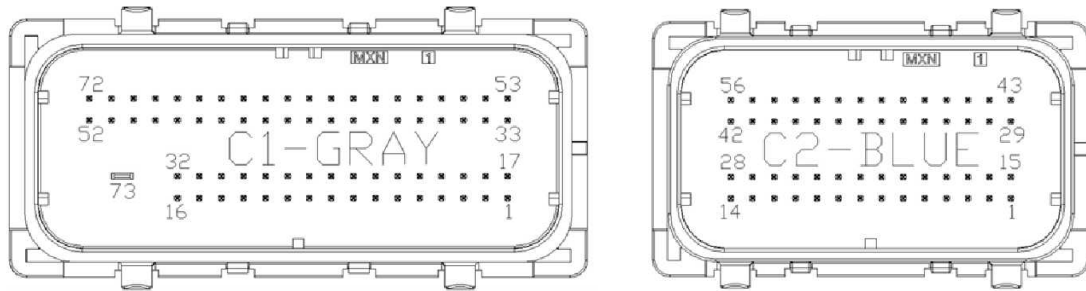

AEM Infinity Connectors Viewed from Wire Side



## 12 MONTH LIMITED WARRANTY

Advanced Engine Management Inc. warrants to the consumer that all AEM High Performance products will be free from defects in material and workmanship for a period of twelve (12) months from date of the original purchase. Products that fail within this 12-month warranty period will be repaired or replaced at AEM's option, when determined by AEM that the product failed due to defects in material or workmanship. This warranty is limited to the repair or replacement of the AEM part. In no event shall this warranty exceed the original purchase price of the AEM part nor shall AEM be responsible for special, incidental or consequential damages or cost incurred due to the failure of this product. Warranty claims to AEM must be transportation prepaid and accompanied with dated proof of purchase. This warranty applies only to the original purchaser of product and is non-transferable. All implied warranties shall be limited in duration to the said 12-month warranty period. Improper use or installation, accident, abuse, unauthorized repairs or alterations voids this warranty. AEM disclaims any liability for consequential damages due to breach of any written or implied warranty on all products manufactured by AEM. Warranty returns will only be accepted by AEM when accompanied by a valid Return Merchandise Authorization (RMA) number. Product must be received by AEM within 30 days of the date the RMA is issued.

Please note that before AEM can issue an RMA for any electronic product, it is first necessary for the installer or end user to contact the EMS tech line at 1-800-423-0046 to discuss the problem. Most issues can be resolved over the phone. Under no circumstances should a system be returned or a RMA requested before the above process transpires.

AEM will not be responsible for electronic products that are installed incorrectly, installed in a non-approved application, misused, or tampered with.

Any AEM electronics product can be returned for repair if it is out of the warranty period. There is a minimum charge of \$50.00 for inspection and diagnosis of AEM electronic parts. Parts used in the repair of AEM electronic components will be extra. AEM will provide an estimate of repairs and receive written or electronic authorization before repairs are made to the product.