

WATER TEMPERATURE SENSOR

PART NUMBER 30-2011

FEATURES

- Design for Manufacturability
- Cost Effective
- Robust Design
- Few Components & Assembly Processes
- Thermistor Technology
- 100% Calibration Certified

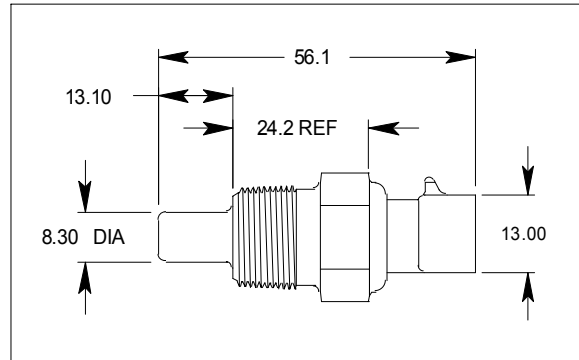

Thermal & Electrical Properties

Typical Voltage Supply	5Vdc
Operating Temperature	-40°C to 135°C
Resistive Range(Ω)	See Table
Dissipation Constant	‡ 24 mW/°C
Thermal Time Constant	‡‡ 20 to 30 seconds
Accuracy	See Table

Mechanical Characteristics

Sensor Body Material	Brass Housing
Connector	PBT 30% GF
Hex Size	18.90mm (3/4")
Thread Size	3/8" - 18 NPT
Validated Sealing Pressure	‡‡‡ 145 kPa
Installation Torque	20 N-m, dynamic
Overall Weight	39.5g

Thermal Time Constant ‡‡

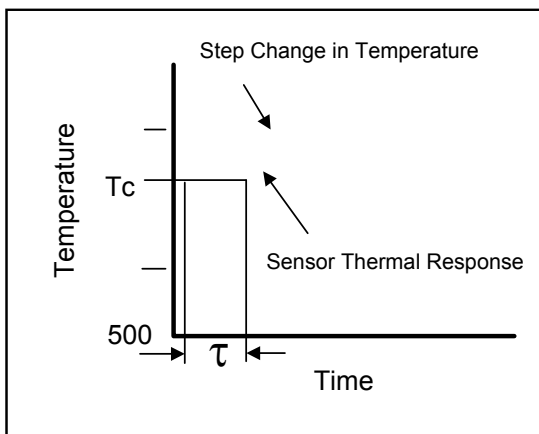

Circuit Schematic

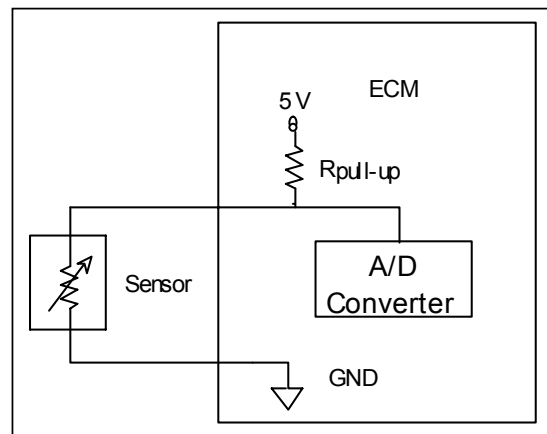

‡ The ratio, at a specified ambient temperature, of the change in the power dissipation of the sensor to the resultant temperature change of the thermistor. Test medium: silicone oil.

‡‡ The time required for the sensor to achieve 63.2% of its steady state value when subjected to a step change in ambient temperature [$T_c = (T_f - T_i) * 63.2\% + T_i$]. Test medium: silicone oil.

‡‡‡ Test fixture fitted with 3/8"-18 NPSF Internal Threads.

WATER TEMPERATURE SENSOR PRODUCT DATA

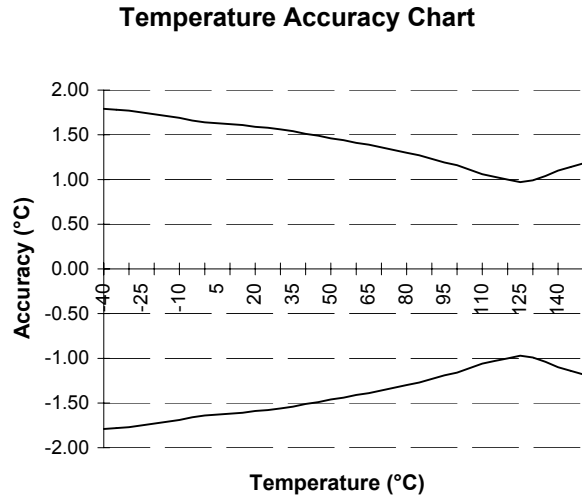
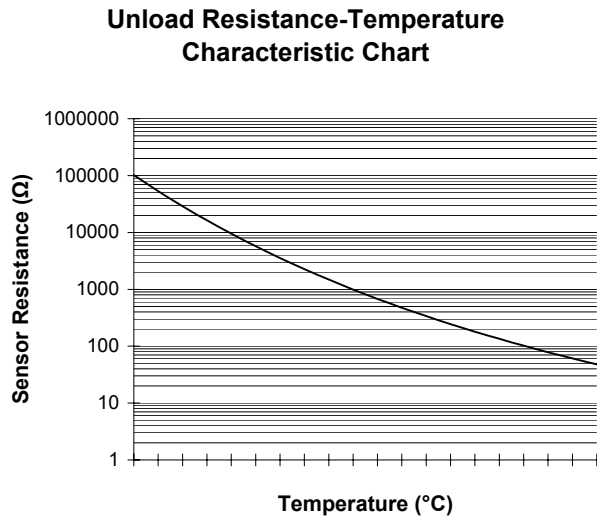

Note: Temperature Sensor Calibration Resistance Guaranteed by 100 % Automated Calibration Certification.

Unloaded Resistance-Temperature Characteristic Table

Temp (°C)	R(Ω)*	R(±%)	Ref. Acc. (±°C)	Temp (°C)	R(Ω)*	R(±%)	Ref. Acc. (±°C)	Temp (°C)	R(Ω)*	R(±%)	Ref. Acc. (±°C)
-40	102,122	12.04	1.8	25	2,830	7.09	1.6	90	244.8	3.87	1.2
-35	73,340	11.58	1.8	30	2,268	6.81	1.6	95	209.7	3.66	1.2
-30	53,249	11.12	1.8	35	1,828	6.53	1.5	100	180.3	3.45	1.2
-25	39,064	10.67	1.8	40	1,483	6.25	1.5	105	155.6	3.22	1.1
-20	28,939	10.24	1.7	45	1,210	5.97	1.5	110	134.7	3.02	1.1
-15	21,637	9.81	1.7	50	992	5.70	1.5	115	117.1	2.84	1.0
-10	16,321	9.39	1.7	55	819	5.45	1.4	120	102.2	2.69	1.0
-5	12,413	8.97	1.7	60	679	5.21	1.4	125	89.4	2.57	1.0
0	9,516	8.57	1.6	65	566	4.98	1.4	130	78.5	2.54	1.0
5	7,354	8.27	1.6	70	475	4.75	1.4	135	69.1	2.62	1.0
10	5,728	7.97	1.6	75	400	4.52	1.3	140	61.1	2.69	1.1
15	4,496	7.67	1.6	80	338	4.30	1.3	145	54.1	2.73	1.1
20	3,555	7.38	1.6	85	287	4.08	1.3	150	48.1	2.76	1.2

Important: The values above are for the unloaded thermistor, as shipped from AEM Performance Electronics, and does not reflect the effects of application system errors and aging.

*Note: Please contact AEM Performance Electronics for the resistance vs. temperature curve for your temperature sensor application. Due to self-heating effects of the thermistor, the resistance is dependent on the application.

Since thermistors are "continuous function devices", resistance vs. temperature data is available for numbers beyond those specified above.

For more information contact:

AEM Performance Electronics
2205 126th Street
Hawthorne, CA. 90250

Phone: (310) 484-2322
Fax: (310) 484-0152
E-mail: tech@aempower.com