

Instruction Manual



P/N 30-0312 X-SERIES GAUGE AEMnet CAN



STOP! - READ THIS BEFORE INSTALL OR USE!

WARNING:

THIS INSTALLATION MAY REQUIRE WELDING OR INTEGRATION INTO A VEHICLE'S ELECTRICAL SYSTEM. DAMAGE TO SENSITIVE ELECTRONICS, FIRE, OR EXPLOSION MAY OCCUR IF PROPER PRECAUTION IS NOT TAKEN. IF THERE IS ANY DOUBT, **DO NOT** ATTEMPT THE INSTALLATION AND CONSULT A PROFESSIONAL.

NOTE: IT IS THE RESPONSIBILITY OF THE ENGINE TUNER TO ULTIMATELY CONFIRM THE CALIBRATION USE FOR ANY PARTICULAR ENGINE IS SAFE FOR ITS INTENDED USE. AEM HOLDS NO RESPONSIBILITY FOR ANY ENGINE DAMAGE THAT RESULTS FROM THE MISUSE OF THIS PRODUCT.

Features

- 2-1/16" / 52mm outer diameter mounting
- 62 AEMnet channels supported
- Supported devices: Infinity ECU, Series 2 ECU, EMS-4, 4 Channel UEGO, X-Series UEGO, VDM
- Auto-hides channels from devices that aren't present
- Ability to hide/show channels from devices that are present
- Peak recall for each channel
- US or Metric / SI display modes
- Black bezel / faceplate supplied; Silver/white available as optional purchase
- Locking connectors
- Auto-dimming
- Supports vehicle / system voltages up to 16V

KIT CONTENTS	
PN	Description
10-0312	INST, X-SERIES AEMNET CAN GAUGE
35-0312	GAUGE ASSY, X-SERIES AEMNET CAN GAUGE
35-8618	NUT, KNURLED, M4x0.7 (2)
35-8614	BRACKET, X-SERIES GAUGE
35-8617	RUBBER BAND, X-SERIES GAUGE
35-3437	CABLE, X-SERIES GAUGE PWR/IO CAN
OPTIONAL ACCESSORIES	
PN	Description
30-0312-ACC	BEZEL, X-SERIES SILVER FACEPLATE, X-SERIES AEMNET, WHITE

Wiring Installation Diagram

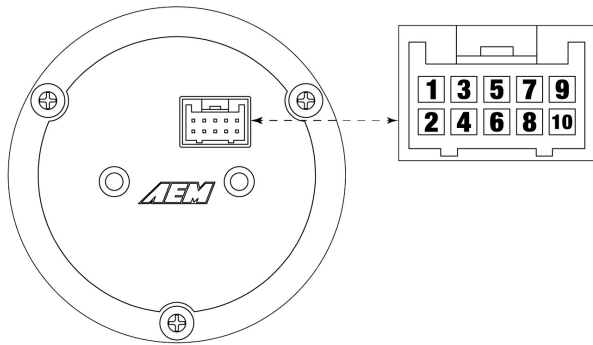
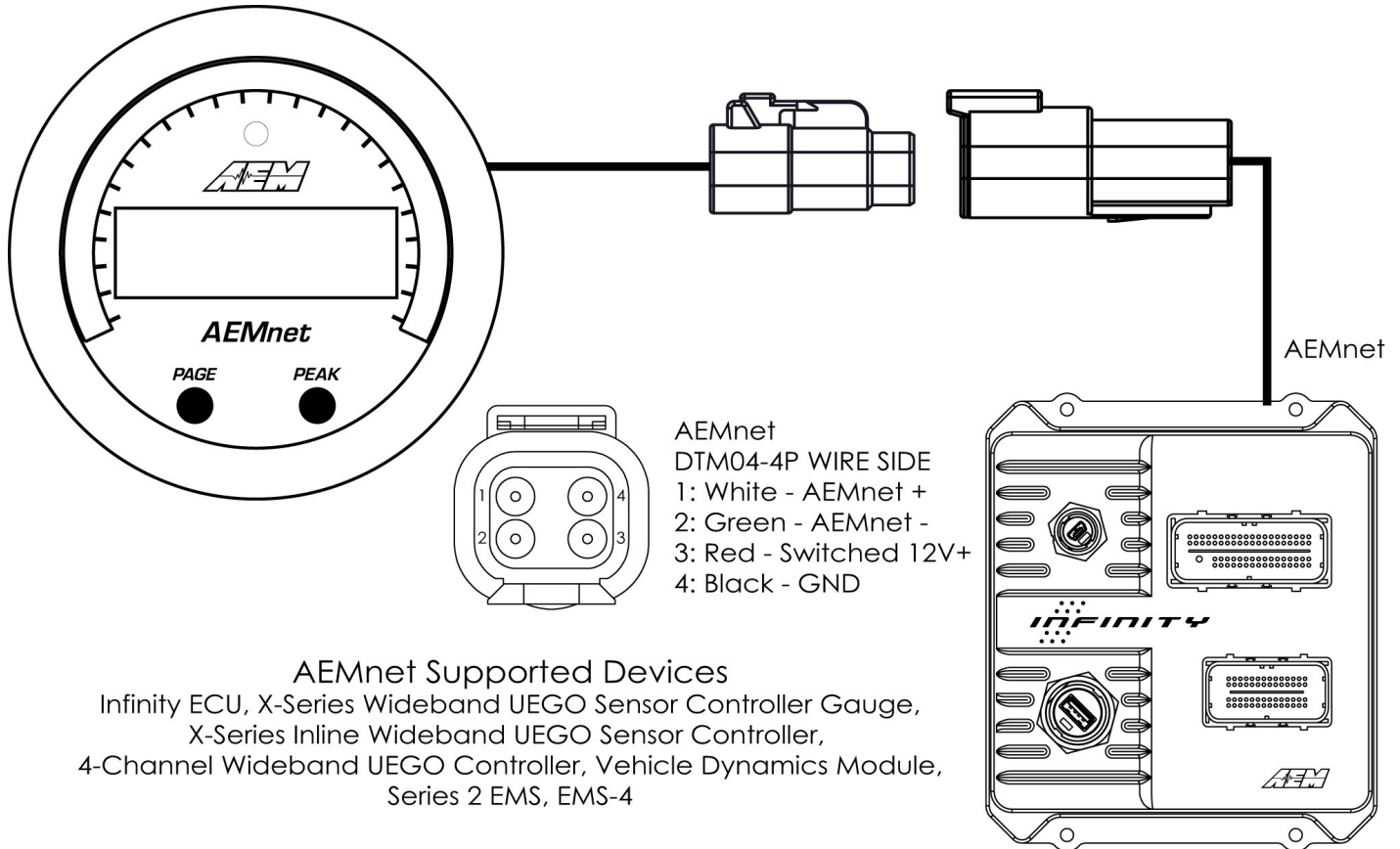

A

Connector A - Power / IO

Pin	Color	Description
1	WHITE	AEMnet- / CANL
2	GREEN	AEMnet+ / CANH
3	RED	Switched 12V Power
4	BLACK	Power Ground
5 - 10	NC	NC

Operation

The PAGE button may be depressed to scroll through the available AEMnet channels; an abbreviation of each channel name will be briefly displayed after each button press.

The inner numeric LEDs and outer ring LED display the currently selected channel reading. Channels will only be present in the channel list if the corresponding AEMnet device is presently connected to the bus, powered, and transmitting. Please reference the AEMnet Channel description table further on in this document.

PAGE and PEAK buttons are located on the face of the gauge and are used to perform various functions, described below.

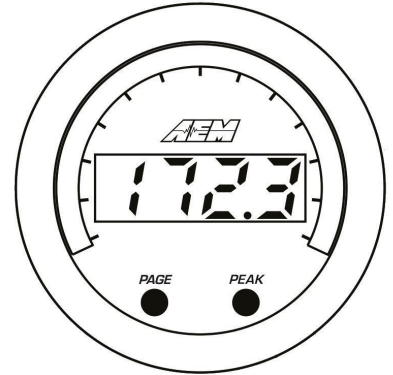

Display or clear stored peak value

- Press the PEAK button; the peak (highest) reading of the currently selected channel will be displayed and the outer LED will flash.
- The peak value will be retained across power cycles.
- While the peak value is being displayed, depress and hold the PEAK button for three seconds until "CLr" appears to clear the peak values.
- This operation will clear the peak values of ALL channels.



Will be displayed to confirm the peak value has been reset

- The gauge will return to normal display mode a few seconds after the last button press

Change channel display units US / SI (metric)

- The gauge should be in its normal display mode, showing the current parameter reading.
- Depress and hold the PAGE button for three seconds until US or SI appears.
- Press the PAGE button to toggle between US or SI (metric) modes.
- This setting will apply to all channels EXCEPT wideband O2 channels.
- The gauge will return to normal display mode a few seconds after the last button press.

Change wideband O2 display units AFR / Lambda

- The gauge should be in its normal display mode, showing a wideband/oxygen sensor channel reading.
- Depress and hold the PAGE button for three seconds until US or SI appears.
- Press the PAGE button to toggle between AFR or Lambda modes.
- This setting will apply to all wideband O2 channels.
- The gauge will return to normal display mode a few seconds after the last button press.

Hide or show channels

If multiple AEMnet devices are present on the bus, the channel list can grow to be quite long, up to 62 channels. This can make it time consuming to scroll through and find a specific channel to display. A hide/show feature is available to remove infrequently viewed channels from the channel list.



- Depress both the PAGE and PEAK buttons to display "HidE" and begin selecting which channels to hide/show in the channel list.
- Use the PAGE button to scroll through the channel list and the depress the PEAK button to toggle between hide and show.
- The gauge will return to normal display mode a few seconds after the last button press.

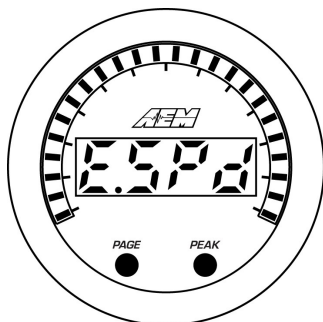

All outer LEDs illuminated = **SHOW**

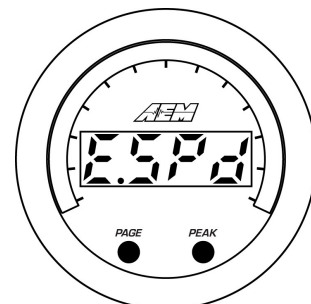

All outer LEDs off = **HIDE**

Faceplate / Bezel Installation

The gauge kit is supplied assembled with a black faceplate and black bezel. An accessory kit is available (for purchase through AEM dealers) which includes an optional silver bezel and white faceplate. Please reference the Optional Accessories section earlier in the document for the appropriate part numbers. Contact your dealer or visit www.aemelectronics.com for more information.

The faceplate may be reversible, displaying alternative scalings on either side. Reference the Operation section of this manual for details on how to switch the display mode when reversing the faceplate. Disassembly is required to change the faceplate, flip/reverse the faceplate, or change the bezel of the gauge. The following diagram will provide familiarization with the major components of the gauge prior to beginning the procedure.

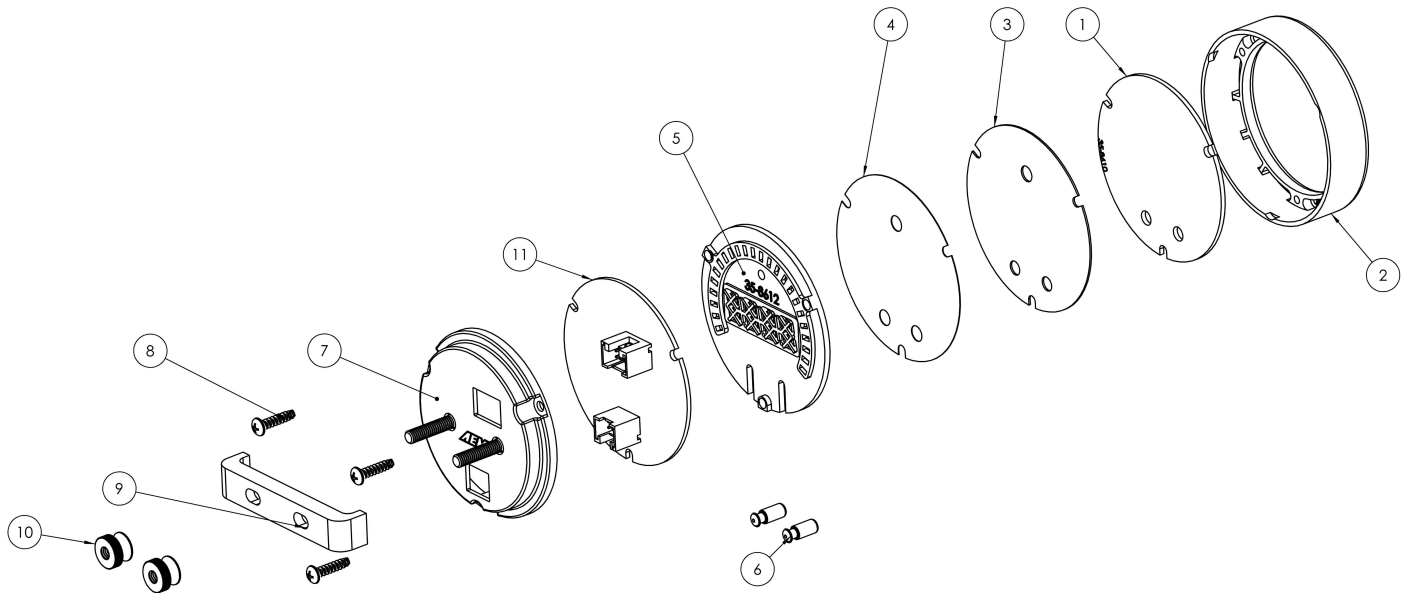

Item	Qty	Description
1	1	Lens
2	1	Bezel
3	1	Faceplate
4	1	Diffuser
5	1	Light Guide
6	2	Button
7	2	Mounting Stud (M4 x 0.7)
8	3	Assembly Screw
9	1	Mounting Bracket
10	2	Brass Thumb Screw (M4 x 0.7)
11	1	Printed Circuit Board (PCB)

Gauge Disassembly

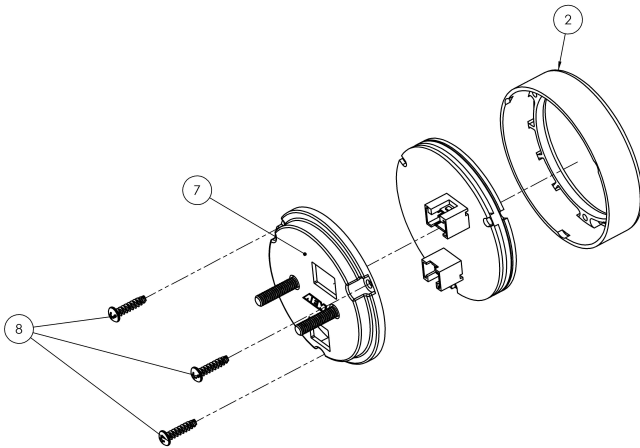

STEP 1 - Remove the three assembly screws (8) using a #1 Phillips head screwdriver. Separate the bezel (2) and cup (7) from the rest of the assembly. If you have purchased the optional accessory kit, the silver bezel may be replaced for the existing bezel at this time

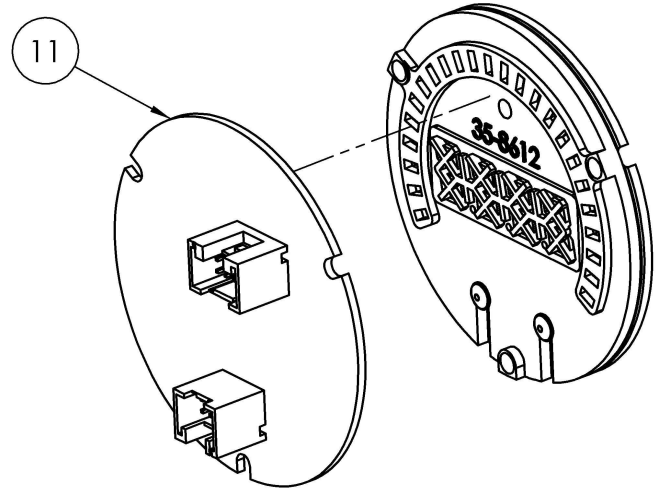

STEP 2 - Separate the PCB (11) from the remaining components

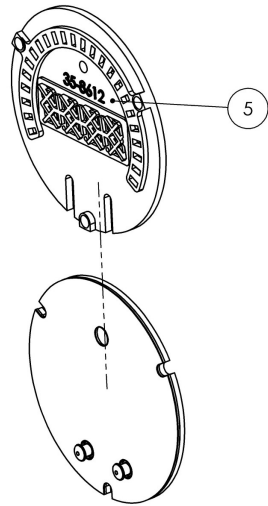

STEP 3 - Slide the light guide (5) upward to remove it, the buttons may fall out at this time - take care not to lose them

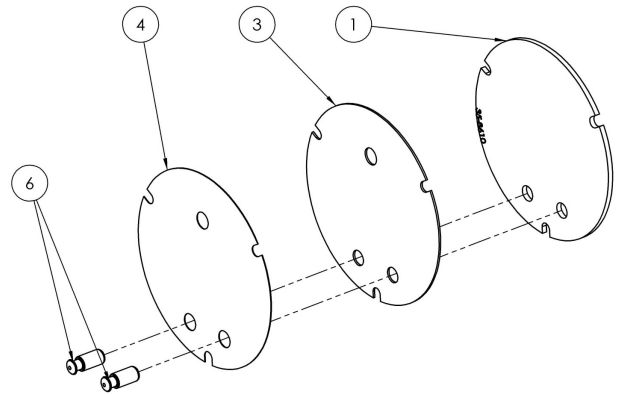

STEP 4 - As you separate the remaining components, diffuser (4), faceplate (3), lens (1), note the order in which they were assembled. The faceplate (3) may now be reversed to display an alternate scaling or replaced for a different color as included in the optional accessory kit

Gauge Assembly

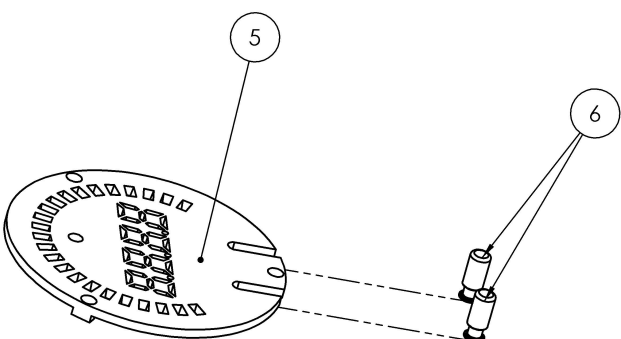
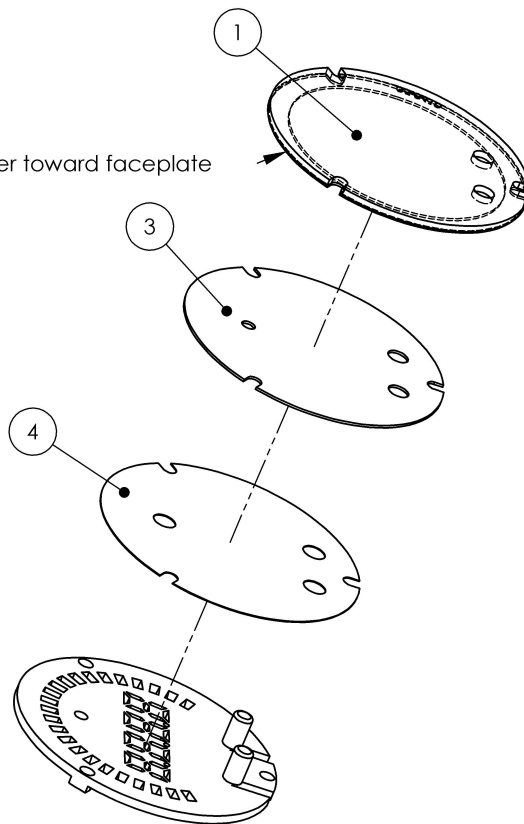
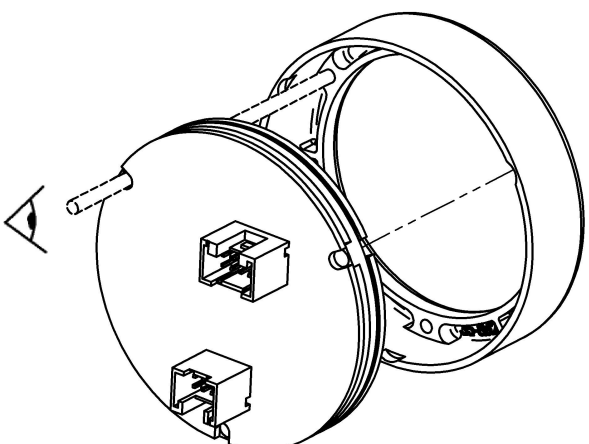
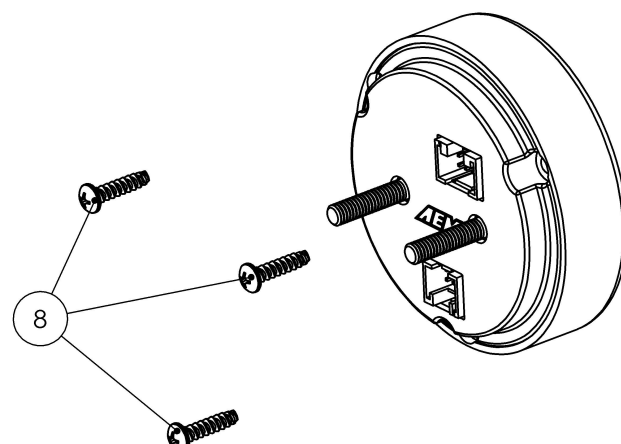
	 <p>Lens spacer toward faceplate</p>
<p>STEP 1 - Place the light guide (5) on a flat surface (black side up) and slide the buttons (6) into the slots</p>	<p>STEP 2 - Stack the diffuser (4), faceplate (3), and lens (1) in order, over the buttons, and on to the light guide</p>
	
<p>STEP 3 - Reassemble the PCB and display stack with the bezel, making sure screw holes are aligned through the entire assembly</p>	<p>STEP 4 - Reassemble and tighten screws to 2 in-lb (previously assembled bezel) or 3 in-lb (new bezel). Do not over-tighten!</p>

Gauge Installation

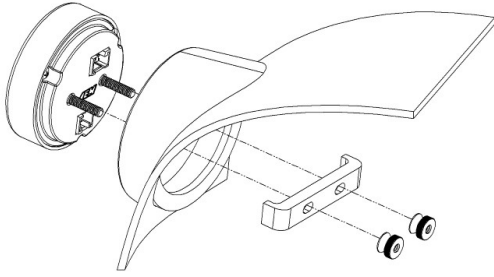

Installation using supplied bracket

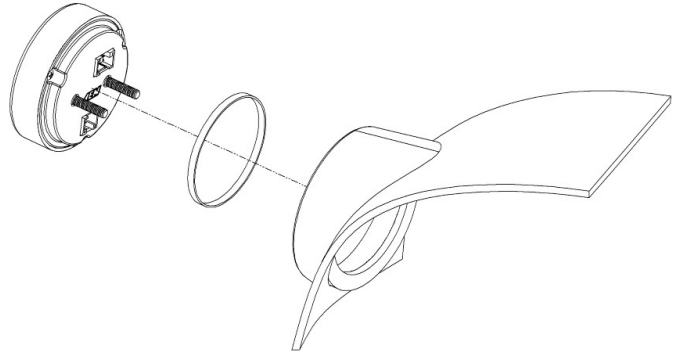

Installation without bracket, using rubber band

A 2-1/6" (52mm) hole is required to mount the X-Series gauge. A bracket and thumbscrews are provided to facilitate installation into a panel or gauge pod. In some cases, the gauge cup may be pushed into a mounting hole causing an interference fit strong enough to retain the gauge; the supplied rubber band may be fit to the gauge to create a tighter fit in mounting holes slightly larger than 52mm. It is, however, recommended that gauges be mounted securely using the supplied bracket to ensure they never become loose and cause a hazard during vehicle operation.

Note: The gauge is not water-proof and should not be installed in a location with exposure to water or snow. Damage caused by water ingress will not be covered under warranty.

AEMnet Channels

Display Label	Description	US	SI	Source
RF Fb	Inj 1 LambdaFB	%	%	Infinity EMS
RFr .1	Lambda 1	AFR	λ	EMS Series 2 / EMS-4 / Infinity
RFr .2	Lambda 2	AFR	λ	EMS Series 2 / EMS-4 / Infinity
ALt	Altitude	ft	m	VDM
bRt	Battery Volts	V	V	EMS Series 2 / EMS-4 / Infinity
bSt d	Boost Control Duty	%	%	Infinity EMS
bSt t	Boost Target	psig	kPa	Infinity EMS
CUt 5	SparkCut [RPM]	rpm	rpm	Infinity EMS
YL .1	Lambda 1	AFR	λ	4 Channel UEGO set on MODE 1
YL .1	Lambda 1	AFR	λ	4 Channel UEGO set on MODE 3
YL .1	Lambda 1	AFR	λ	4 Channel UEGO set on MODE 6
YL .2	Lambda 2	AFR	λ	4 Channel UEGO set on MODE 1
YL .2	Lambda 2	AFR	λ	4 Channel UEGO set on MODE 4
YL .2	Lambda 2	AFR	λ	4 Channel UEGO set on MODE 6
YL .3	Lambda 3	AFR	λ	4 Channel UEGO set on MODE 1
YL .3	Lambda 3	AFR	λ	4 Channel UEGO set on MODE 3
YL .3	Lambda 3	AFR	λ	4 Channel UEGO set on MODE 6
YL .4	Lambda 4	AFR	λ	4 Channel UEGO set on MODE 1
YL .4	Lambda 4	AFR	λ	4 Channel UEGO set on MODE 4
YL .4	Lambda 4	AFR	λ	4 Channel UEGO set on MODE 7
YL .5	Lambda 5	AFR	λ	4 Channel UEGO set on MODE 2
YL .5	Lambda 5	AFR	λ	4 Channel UEGO set on MODE 3
YL .5	Lambda 5	AFR	λ	4 Channel UEGO set on MODE 7
YL .6	Lambda 6	AFR	λ	4 Channel UEGO set on MODE 2
YL .6	Lambda 6	AFR	λ	4 Channel UEGO set on MODE 4
YL .6	Lambda 6	AFR	λ	4 Channel UEGO set on MODE 7

30-0312 - AEMnet CAN

LYL 7	Lambda 7	AFR	λ	4 Channel UEGO set on MODE 2
LYL 7	Lambda 7	AFR	λ	4 Channel UEGO set on MODE 3
LYL 8	Lambda 8	AFR	λ	4 Channel UEGO set on MODE 2
LYL 8	Lambda 8	AFR	λ	4 Channel UEGO set on MODE 4
ESpd	Engine Speed	rpm	rpm	EMS Series 2 / EMS-4 / Infinity
ETH	FlexContent	%	%	Infinity EMS
G Ldt	Lateral Acceleration	g	g	VDM
G Lon	Inline Acceleration	g	g	VDM
G SPd	Vehicle Speed	mph	kph	VDM
GEARr	Gear Calculated	n/a	n/a	EMS Series 2 / EMS-4 / Infinity
IGN r	Knock FB (max)	deg	deg	Infinity EMS
IGN t	Ignition Timing	deg	deg	EMS Series 2 / EMS-4 / Infinity
Inj d	Primary Inj Duty %	%	%	Infinity EMS
Load	Load	%	%	EMS Series 2 / EMS-4
o2-1	Lambda 1	AFR	λ	X-Series UEGO devices
o2-2	Lambda 2	AFR	λ	X-Series UEGO devices
o2-3	Lambda 3	AFR	λ	X-Series UEGO devices
o2-4	Lambda 4	AFR	λ	X-Series UEGO devices
o2-5	Lambda 5	AFR	λ	X-Series UEGO devices
o2-6	Lambda 6	AFR	λ	X-Series UEGO devices
o2-7	Lambda 7	AFR	λ	X-Series UEGO devices
o2-8	Lambda 8	AFR	λ	X-Series UEGO devices
Pbr0	Baro Press	inHg	kPa	Infinity EMS
PbSt	MAP	psig	kPa	Infinity EMS
PCLt	Coolant Pressure	psig	bar	Infinity EMS
PFUE	Fuel Pressure	psig	bar	Infinity EMS
POIL	Oil Pressure	psig	bar	Infinity EMS
PPRn	Crankcase Pressure	psig	kPa	Infinity EMS
SLIP	TC_SlipMeasured	mph	kph	Infinity EMS
SPd	Vehicle Speed	mph	kph	EMS Series 2 / EMS-4 / Infinity
TAAb	Airbox Temp	degF	degC	Infinity EMS
TCLE	Coolant Temp	degF	degC	EMS Series 2 / EMS-4 / Infinity
TAIRt	Intake Air Temp	degF	degC	EMS Series 2 / EMS-4 / Infinity
TOIL	Oil Temp	degF	degC	Infinity EMS
TErn	Trans Temp	degF	degC	Infinity EMS
TPS	Throttle	%	%	EMS Series 2 / EMS-4 / Infinity

FAQ / Troubleshooting

I installed my gauge correctly and the display just shows "CAN"

The gauge is not detecting the expected AEMnet/CAN traffic. Please check that you have other AEMnet enabled devices connected to the bus, properly terminated, and powered on. For custom installations, refer to the Bosch CAN 2.0b specification for proper wiring and termination techniques.

What pins are used in the connector?

To populate optional extras, use JST P/N SPUD-001T-P0.5 terminals for 22-26 AWG wire.

For support, contact AEM Technical Support at 1-800-423-0046 or gentech@aemelectronics.com.

Specifications

Dimensions	diameter (bezel)	2.40	in
	diameter (cup)	2-1/16	in
	depth (incl. bezel)	0.825	in
	depth (cup only)	0.200	in
Supply Voltage	min	10	VDC
	max	18	VDC
Supply Current (13.8V)	nominal	50.0	mA
Operating Temperature	min	-4 / -20	degF / degC
	max (16V Supply)	185 / 85	degF / degC

12 Month Limited Warranty

Advanced Engine Management Inc. warrants to the consumer that all AEM High Performance products will be free from defects in material and workmanship for a period of twelve (12) months from date of the original purchase. Products that fail within this 12-month warranty period will be repaired or replaced at AEM's option, when determined by AEM that the product failed due to defects in material or workmanship. This warranty is limited to the repair or replacement of the AEM part. In no event shall this warranty exceed the original purchase price of the AEM part nor shall AEM be responsible for special, incidental or consequential damages or cost incurred due to the failure of this product. Warranty claims to AEM must be transportation prepaid and accompanied with dated proof of purchase. This warranty applies only to the original purchaser of product and is non-transferable. All implied warranties shall be limited in duration to the said 12-month warranty period. Improper use or installation, accident, abuse, unauthorized repairs or alterations voids this warranty. AEM disclaims any liability for consequential damages due to breach of any written or implied warranty on all products manufactured by AEM. Warranty returns will only be accepted by AEM when accompanied by a valid Return Merchandise Authorization (RMA) number. Product must be received by AEM within 30 days of the date the RMA is issued.

UEGO oxygen sensors are considered wear items and are not covered under warranty.

Please note that before AEM can issue an RMA for any electronic product, it is first necessary for the installer or end user to contact the EMS tech line at 1-800-423-0046 to discuss the problem. Most issues can be resolved over the phone. Under no circumstances should a system be returned or a RMA requested before the above process transpires.

AEM will not be responsible for electronic products that are installed incorrectly, installed in a non-approved application, misused, or tampered with.

Any AEM electronics product can be returned for repair if it is out of the warranty period. There is a minimum charge of \$50.00 for inspection and diagnosis of AEM electronic parts. Parts used in the repair of AEM electronic components will be extra. AEM will provide an estimate of repairs and receive written or electronic authorization before repairs are made to the product.