



FUEL RAIL AN ADAPTER KIT

Installation Instructions for part number:

25-391

1989-1999 Mitsubishi Eclipse Turbo 4G63
Fuel Rail AN Adapter Kit

WARNING:

The installation of this Fuel Rail Kit requires the removal and installation of fuel system components. Improper assembly/installation may result in bodily injury or property damage. If you are not qualified to perform this installation, please refer the installation to a professional. Read and understand these instructions before attempting to install this product.

ADVANCED ENGINE MANAGEMENT INC.
2205 126TH Street, Unit A Hawthorne, CA. 90250
Phone: (310) 484-2322 Fax: (310) 484-0152
[Http://www.aempower.com](http://www.aempower.com)
Part Number: 10-381

© 2002 Advanced Engine Management, Inc.

Read and understand these instructions **BEFORE** attempting to install this product.

! WARNING

- Do not smoke while working on the fuel system.
- Keep open flames or sparks away from your work area.
- Be sure to relieve fuel pressure before working on fuel system.

1) Getting started

- a) Make sure vehicle is parked on a level surface.
- b) Set parking brake.
- c) If engine has run within the past two hours let it cool down.
- d) Clean area around the fuel rail so that dirt cannot get into the engine.

Note it is recommended to:

- Replace all cushion rings, seal rings and fuel injector insulators when fuel rail is disassembled.

2) Disassembly of the AEM Fuel Rail

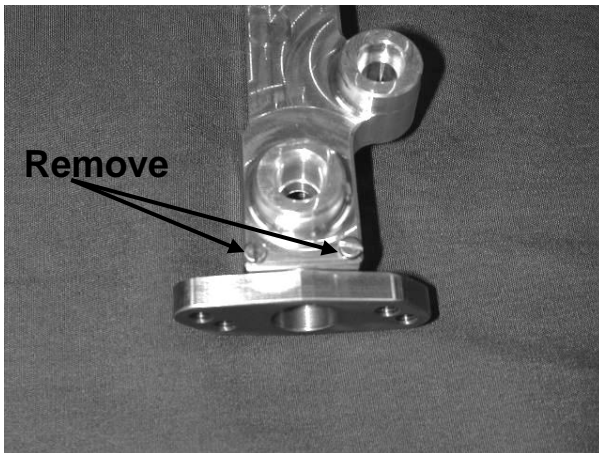

a) Remove the two flathead screws from the bottom of the fuel rail.

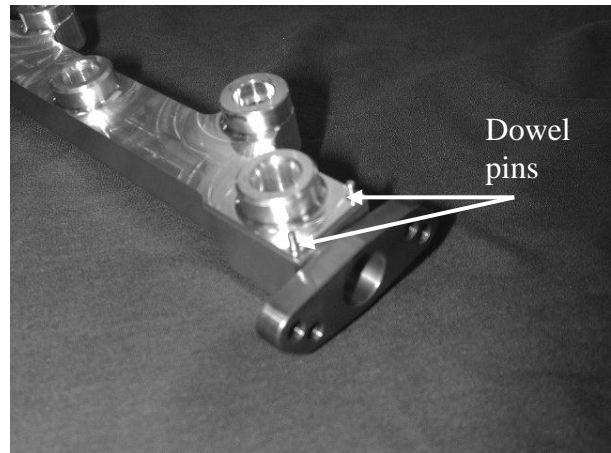

b) Remove the dowel pins from the holes exposed by the removal of the screws. It may be necessary to push them through from the access holes in the top of the rail using a paper clip.

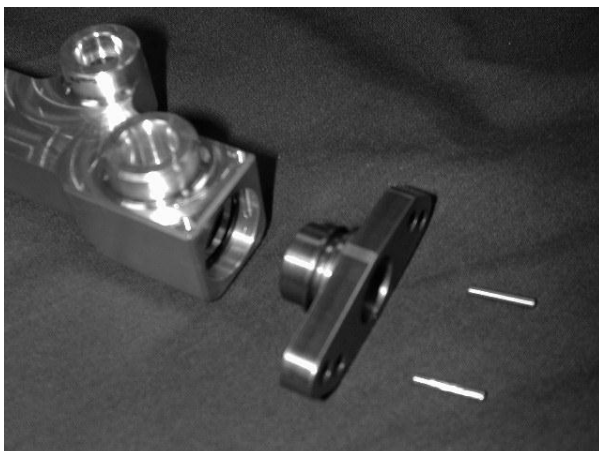

c) Pull the end adapter out of the fuel rail. Remove the old o-rings and thoroughly clean all surfaces.

3) Assembly of the AEM Fuel Rail

Warning: Improper assembly of the AEM fuel rail may result in leakage. Be sure to pressure test the fuel rail on the vehicle before starting the engine or test-driving. If there is any sign of leakage, the problem must be corrected before proceeding.



a) Make sure both ends of the fuel rail are clean and free of debris and burrs.



b) Insert one 1-3024 o-ring into the inner groove. Make sure the o-ring is evenly seated in the groove.

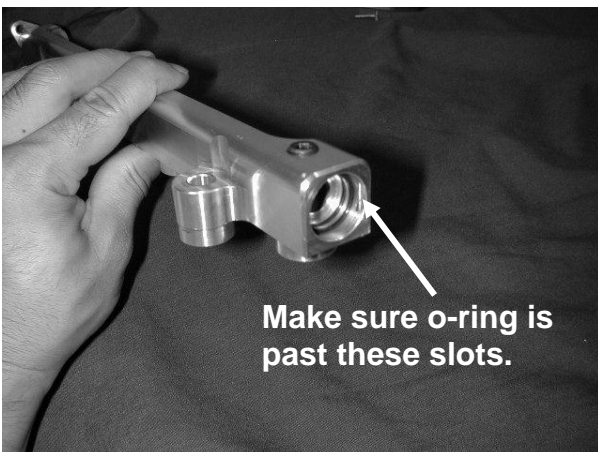

Make sure o-ring is past these slots.

c) Insert another 1-3024 o-ring up against the first shoulder. **Make sure the o-ring is seated evenly against the shoulder and is past the slots for the dowel pins.**

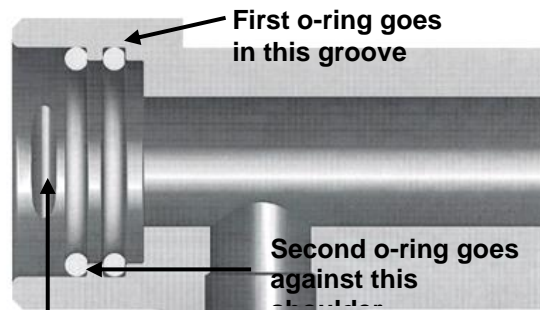

O-rings **MUST** be past the dowel pin slot

d) Refer to this cut-away view for proper o-ring installation. **Warning: The o-rings MUST be properly seated as shown in this diagram. Improper installation may damage the o-rings and cause leakage.**

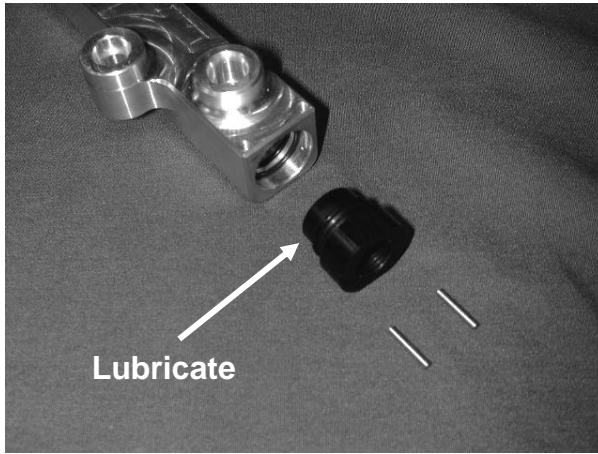

e) Lightly lubricate the tip of the end adapter and the o-rings in the end of the fuel rail. Clean engine oil works well.

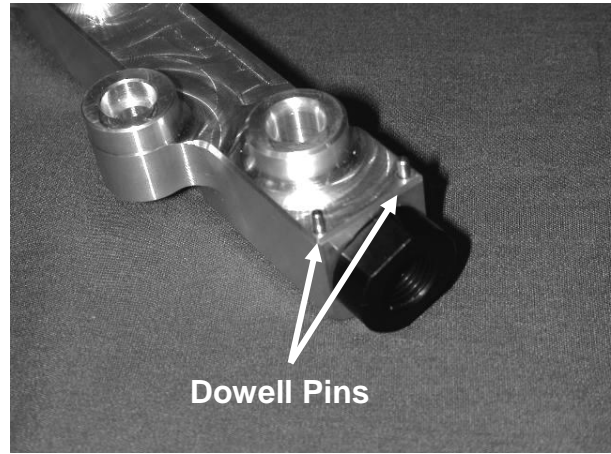

f) **Gently** insert the end adaptor into the fuel rail. Make sure the o-rings stay in place and are not torn. Insert two 1-2061 dowel pins into the dowel pin holes.



g) Insert and tighten two 1-2062 screws into the dowel pin holes. Repeat steps b-g for the other side of the fuel rail.

4) Plumbing the AEM Fuel Rail

The AEM AN Adapter Kit is intended for use in custom fuel system applications. The AEM Universal Fuel Pressure Regulator (P/N 25-302) may be mounted in a remote location and plumbed into the fuel system using this kit. Shown below are suggested methods for attaching AN style lines to the AEM Fuel Rail. Final fuel system configuration and plumbing is up to the end user.

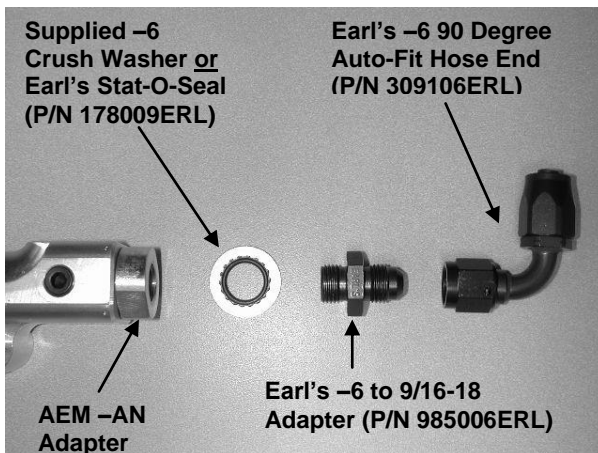

This configuration works well on the **inlet side** of the fuel rail **only**. A line needs to be made from the fuel filter to the fuel rail. **Because this configuration extends off of the fuel rail so far, it is not suitable for the return side of the fuel rail.** The hose end will come into contact with the timing belt cover if this configuration is used on the return side of the fuel rail.

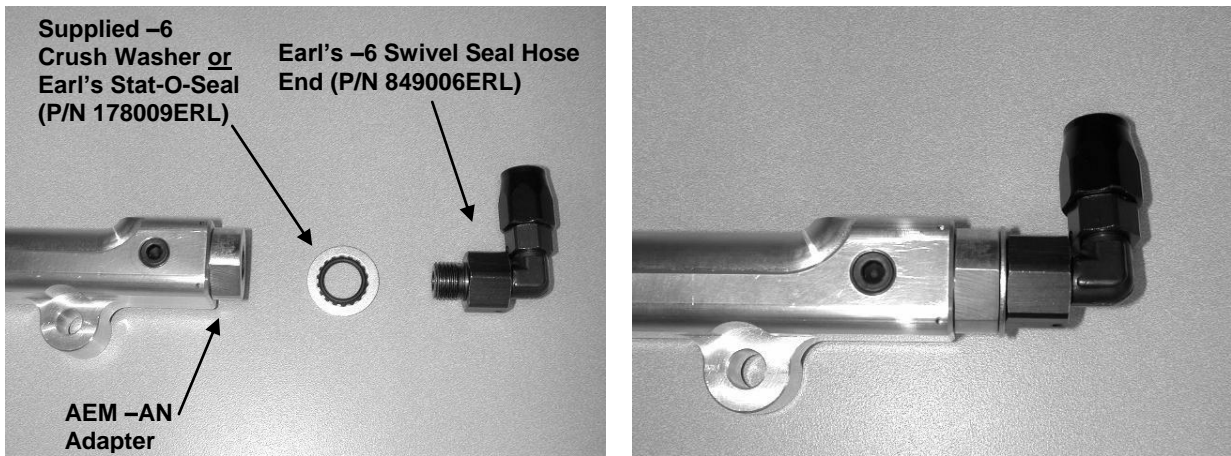

This configuration works well on either the inlet or return side of the fuel rail. A line needs to be constructed from the filter to the rail on the inlet side of the fuel rail. On the return side of the fuel rail, a line needs to be made from the rail to the remote mounted regulator (**AEM** P/N 25-302), and from the regulator's outlet port to the vehicle's fuel return line.

5) Finishing Touches

- a) Connect the negative battery terminal.
- b) Turn the ignition switch to the on position for approximately two seconds. **Do not operate the starter.** Then turn the ignition switch to the off position.
- c) Repeat this procedure three times, and then check all components that were removed during installation for any signs of fuel leakage.
 - i. **Be sure to check the area around the fuel inlet fitting, the injectors, the regulator, and the 1/8" NPT plug. If these items were not installed correctly, they may be prone to leakage.**
- d) **If there are signs of leakage you MUST correct the leak before proceeding.**
- e) If there are no signs of leakage, then start engine and again check for leaks. If there is any sign of leaking you **MUST** repair the leak before driving the vehicle.

**For Technical Inquiries
Please E-Mail us at
tech@aempower.com**

Bill of Materials for Kit # 25-391

Qty.	Part Number	Description
2	2-645	Mitsubishi AN Adapter
4	1-3024	O-Ring (BUNA 70)
2	1-3007	Crush Washer, -6
1	10-381	Instructions